

ATTIX 33M - ATTIX 44M

ATTIX 33H - ATTIX 44H

Instructions for use

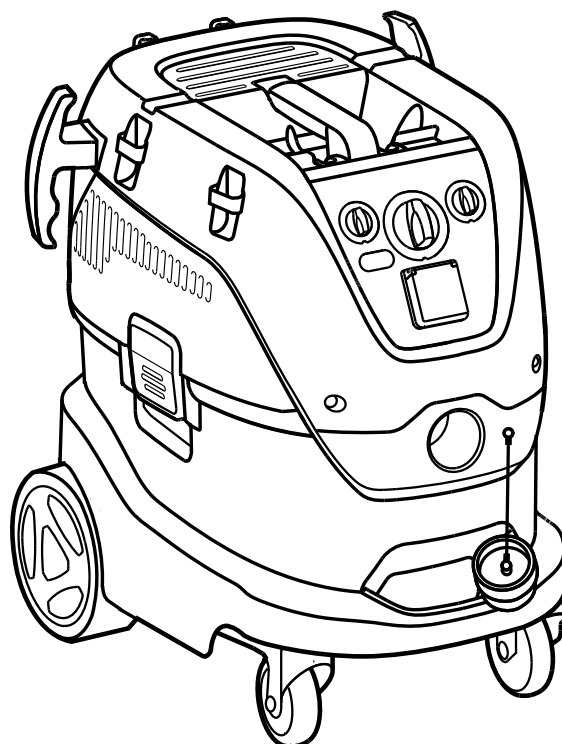
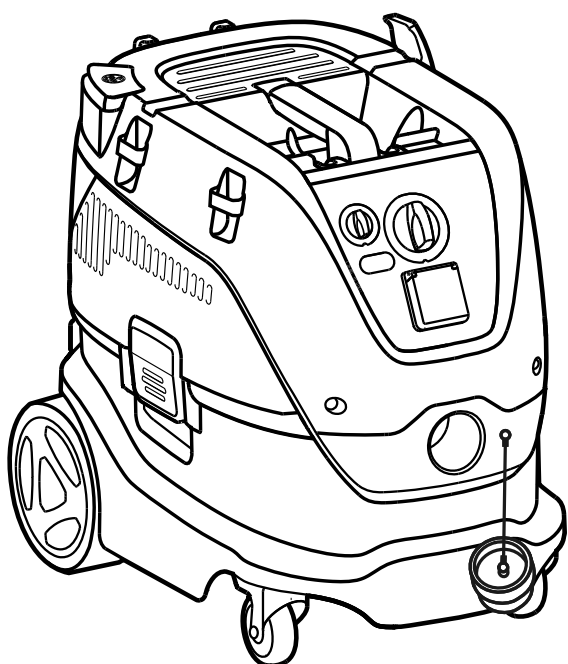

EN	Operating instructions	1
DE	Bedienungsanweisungen	11
FR	Instructions de fonctionnement	22
NL	Gebruiksaanwijzingen	33
IT	Istruzioni per l'uso	44
NO	Bruksanvisning	55
SV	Bruksanvisning	65
DA	Betjeningsvejledning	75
FI	Käyttöohje	85
ES	Instrucciones de funcionamiento	95
PT	Instruções de Funcionamento	106
EL	Οδηγίες λειτουργίας	117
TR	Kullanma Talimatları	129
SL	Navodila za delovanje	140
HR	Upute za uporabu	150
SK	Návod na obsluhu	160
CS	Návod k obsluze	171
PL	Instrukcje dotyczące obsługi	181
HU	Használati útmutató	192
RO	Instrucțiuni de utilizare	203
BG	Указания за експлоатация	214
RU	Руководство по эксплуатации	226
ET	Tööjuhised	238
LV	Norādījumi par ekspluatāciju	248
LT	Naudojimo instrukcija	258
JA	作手順.....	268
ZH	操作说明	278
KO	사용법.....	286
TH	คำแนะนำการใช้งาน	296
MS	Arahan Operasi.....	306

33-2M PC
33-2H PC

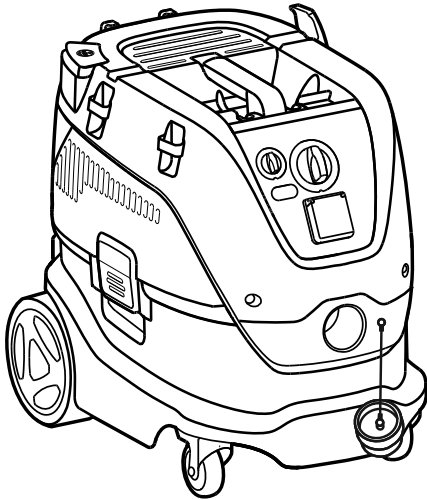

44-2M PC
44-2H PC

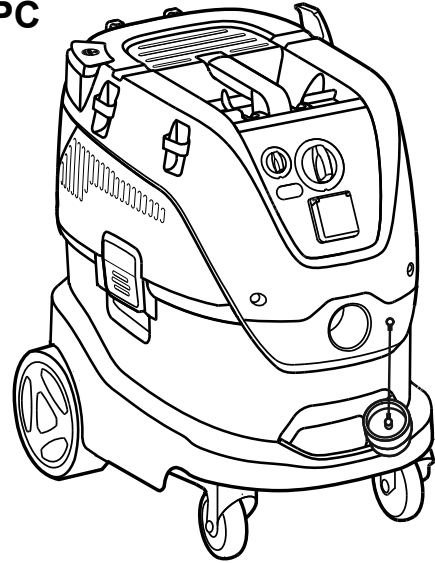

33-2M IC
33-2H IC

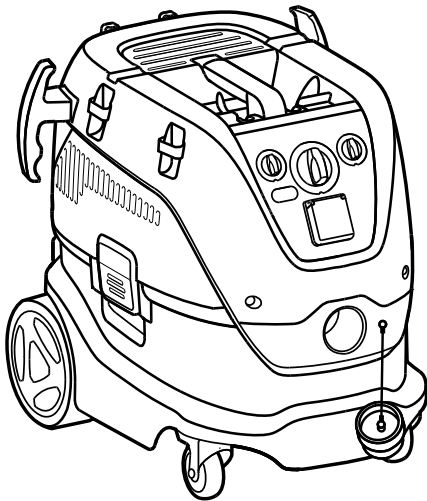

44-2M IC
44-2H IC

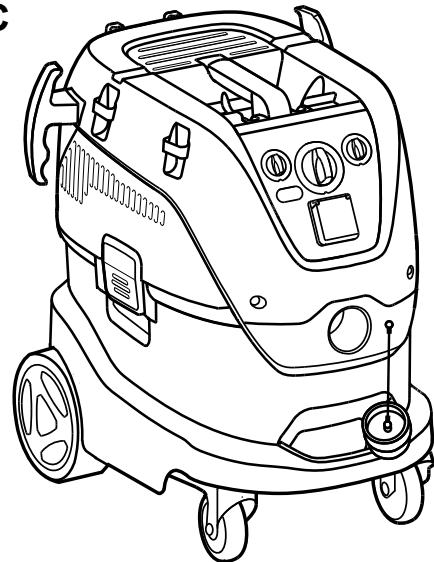

33-2M IC Mobile
33-2H IC Mobile

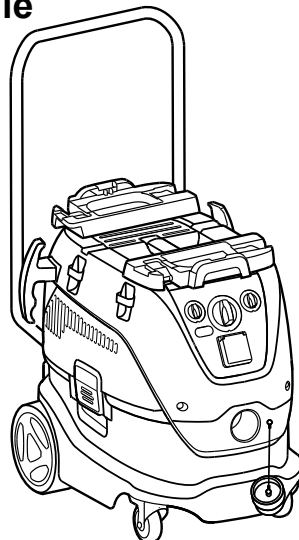

44-2M IC Mobile
44-2H IC Mobile

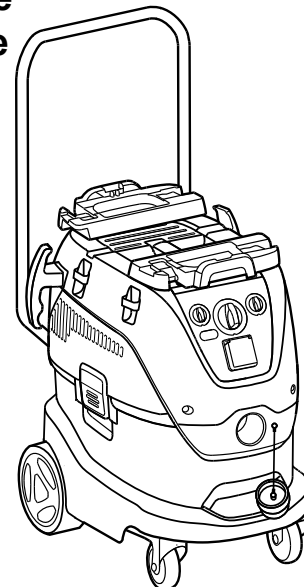

Operating elements

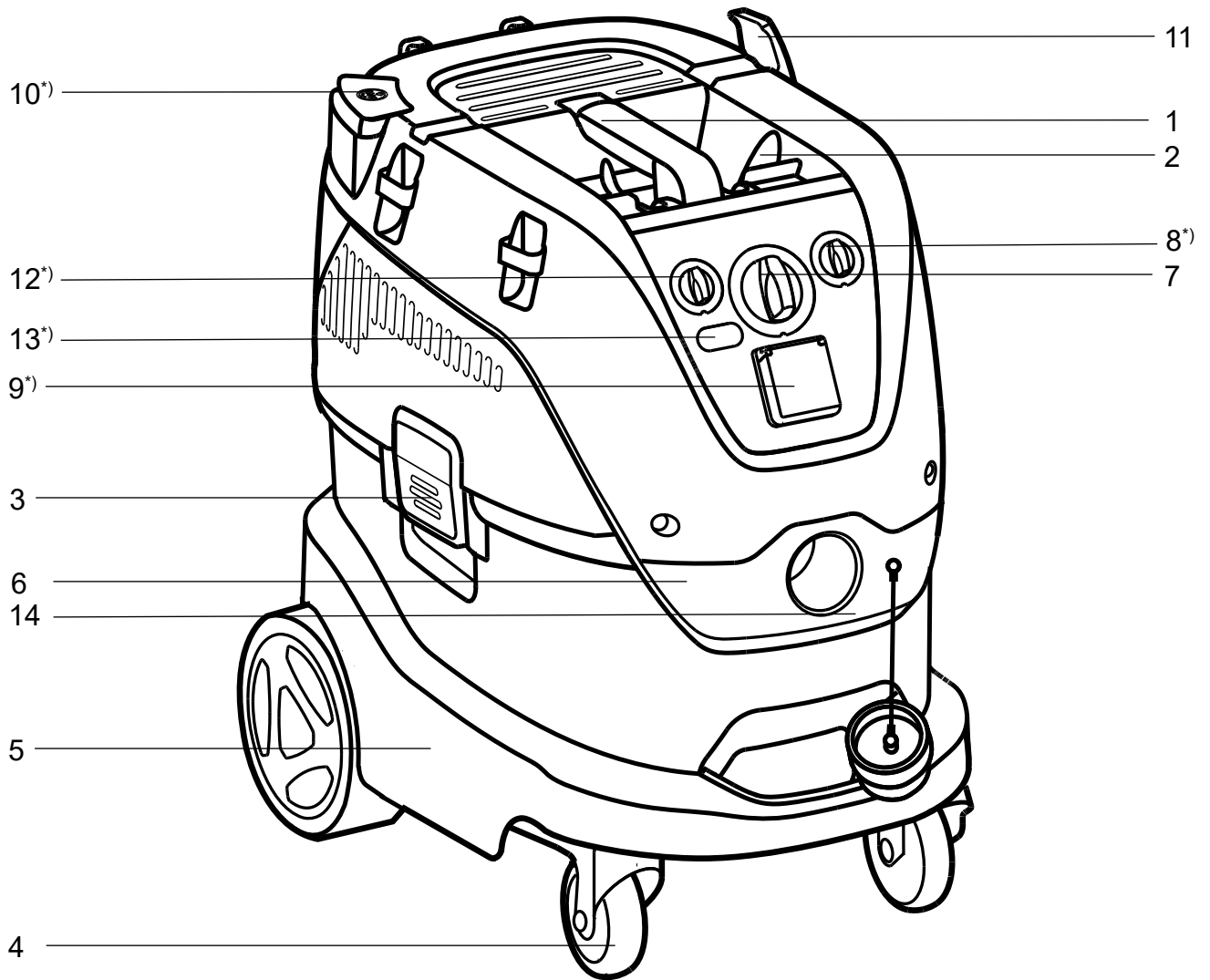

1A)



2A

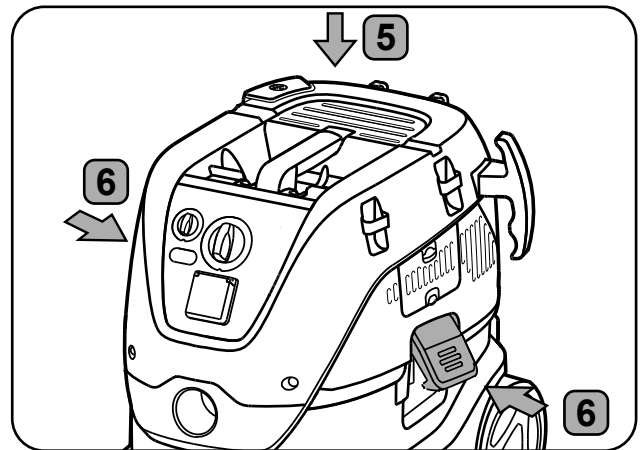
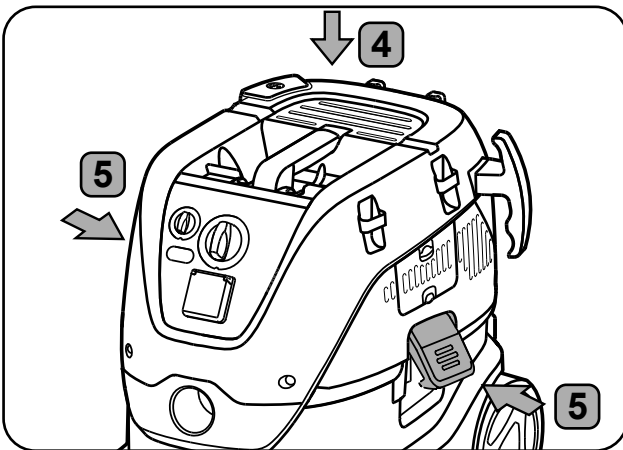
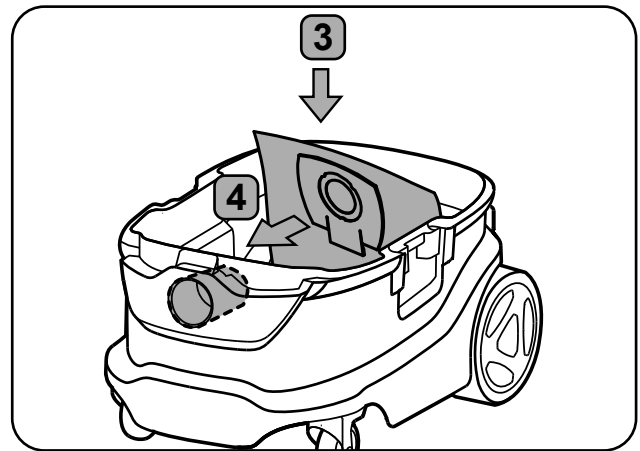
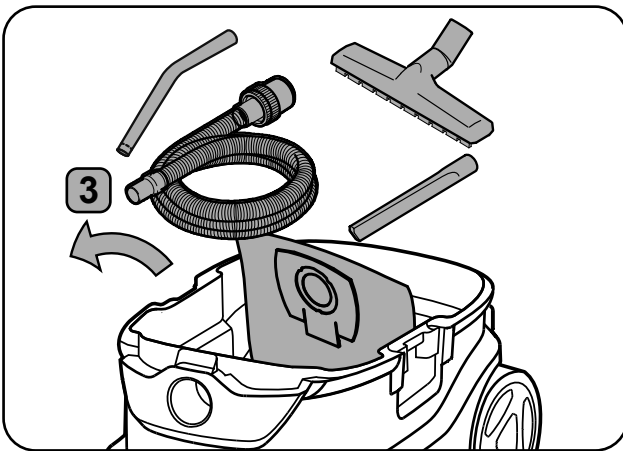
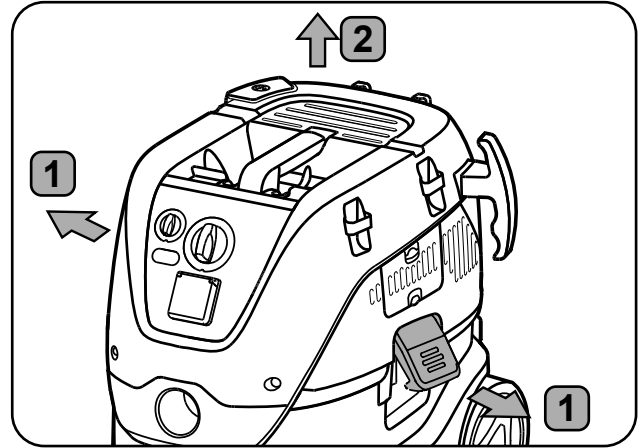
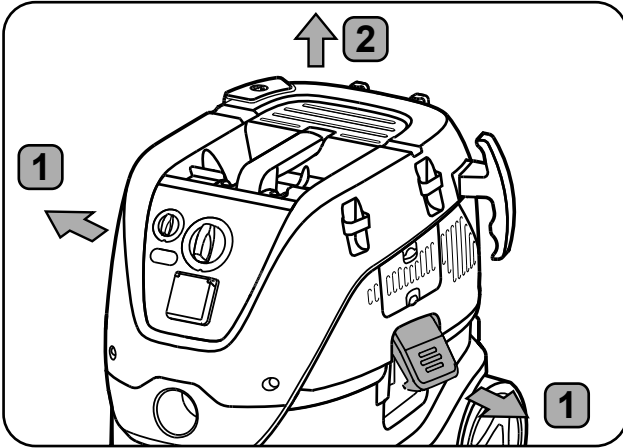

3A)



4A

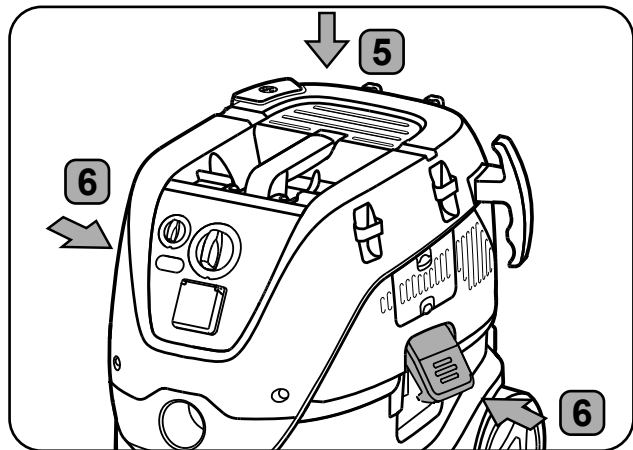
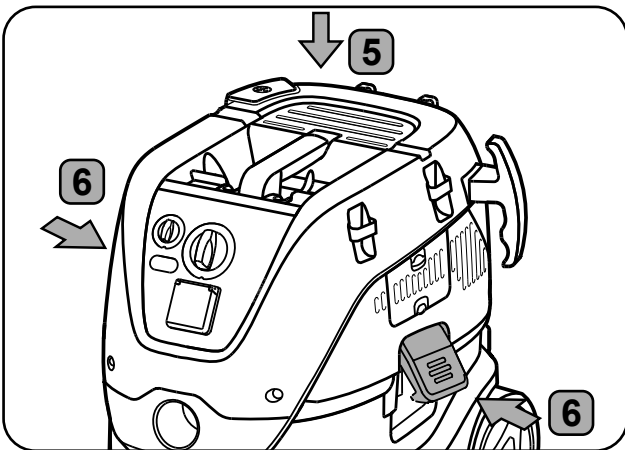
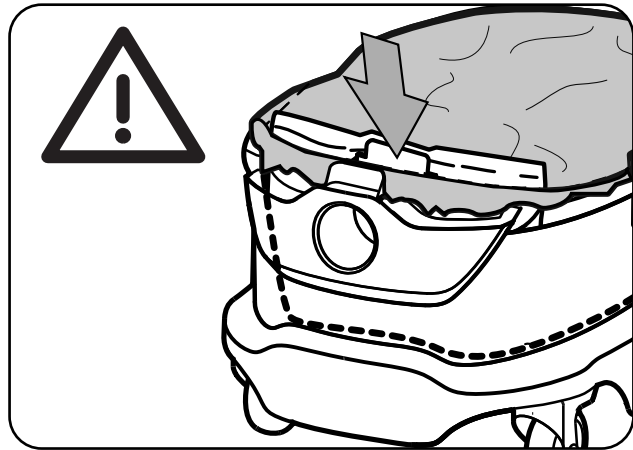
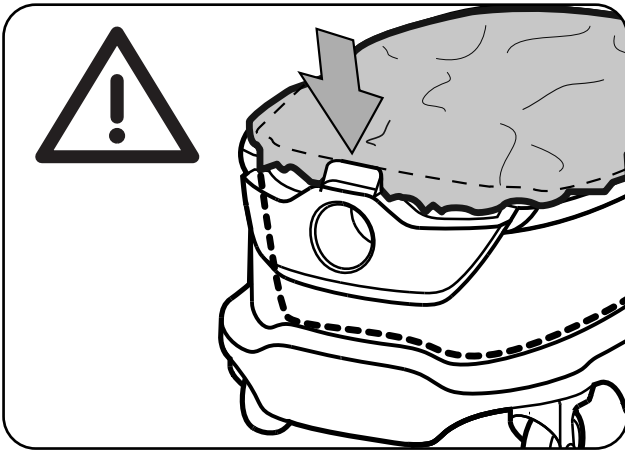
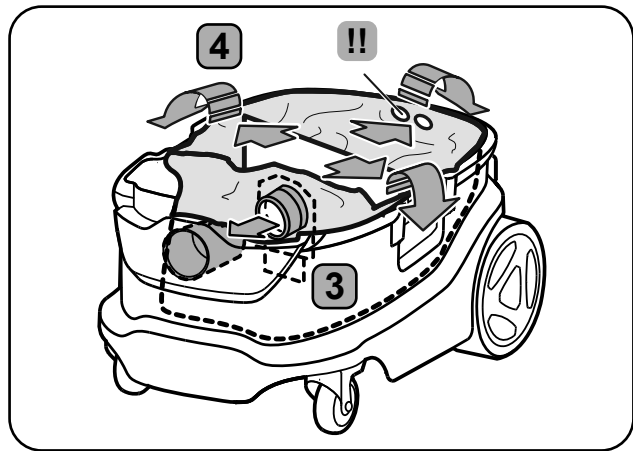
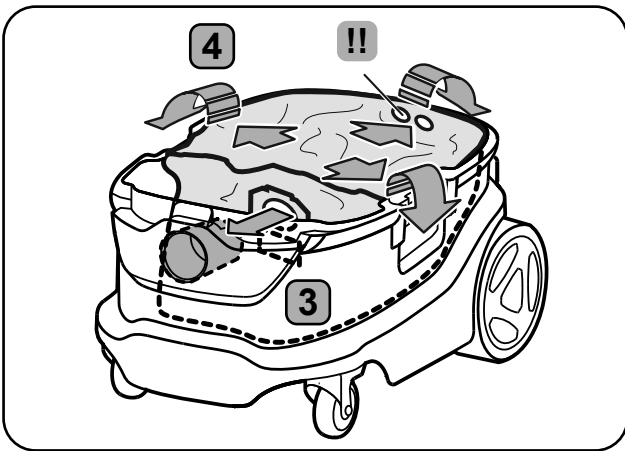
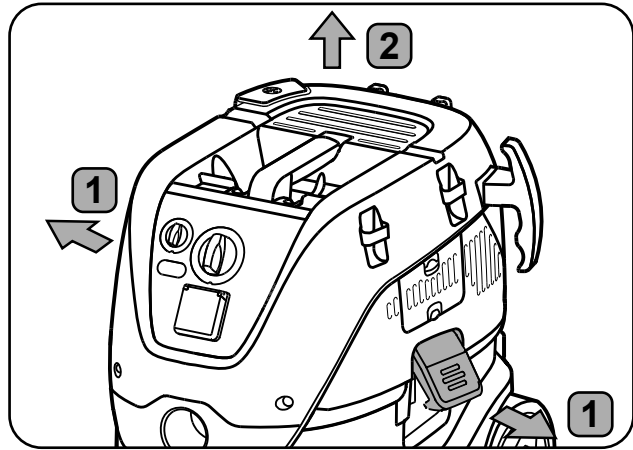
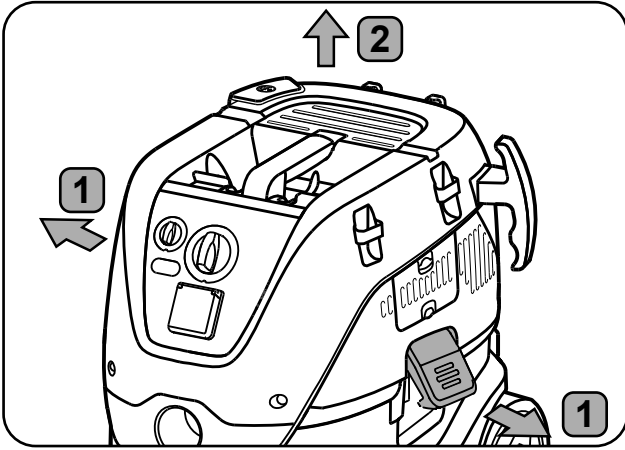

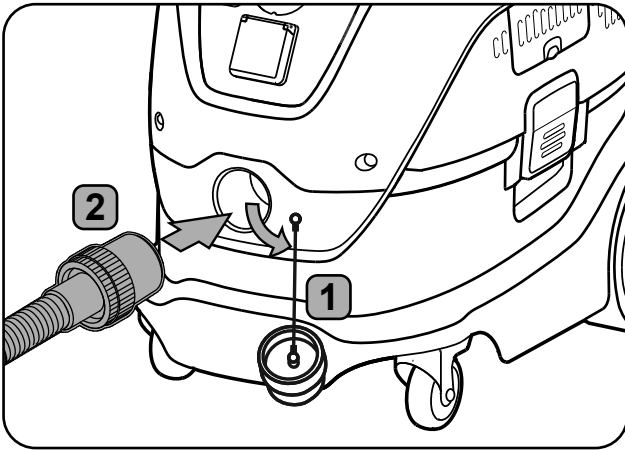

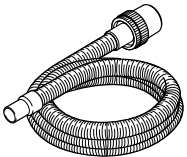
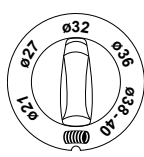
	3 
ø21	ø21
ø27	ø27
ø32	ø32
ø36	ø36
ø38-40	ø38-40

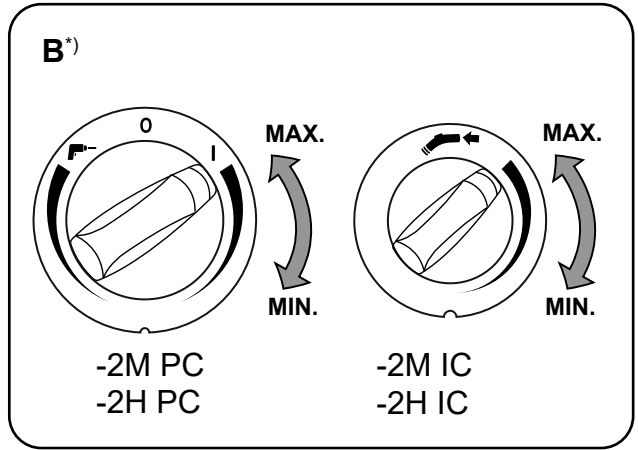
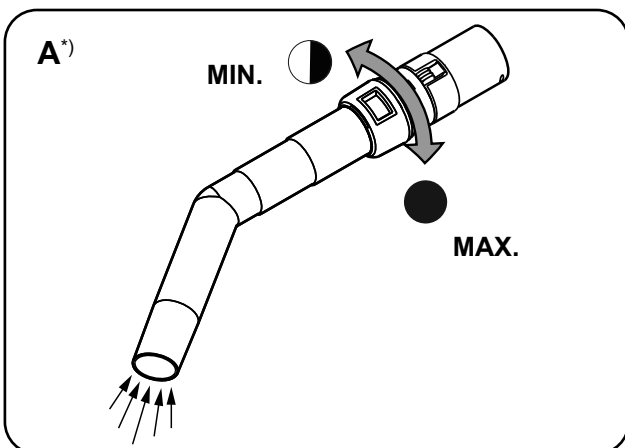
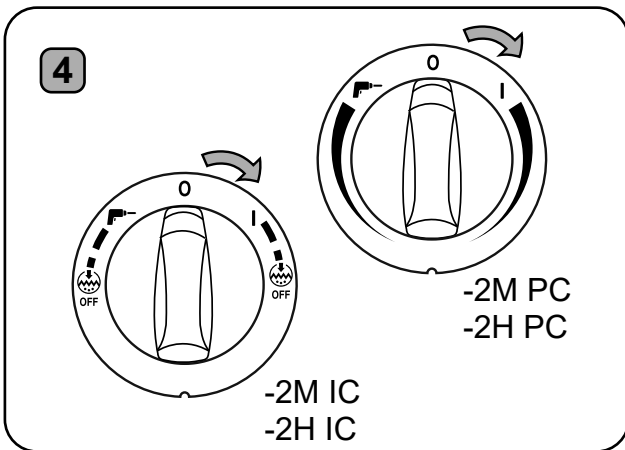

6A¹⁾

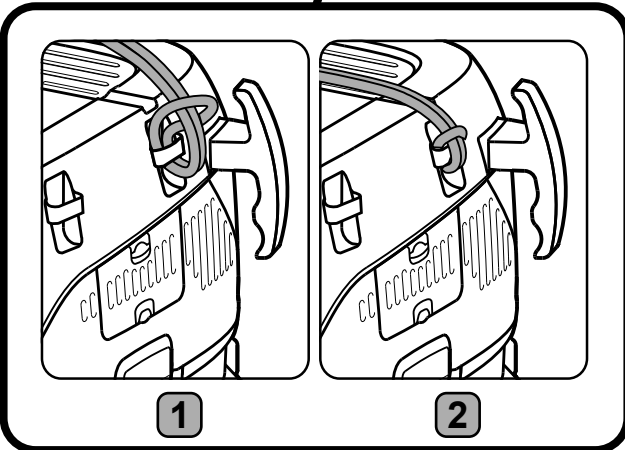
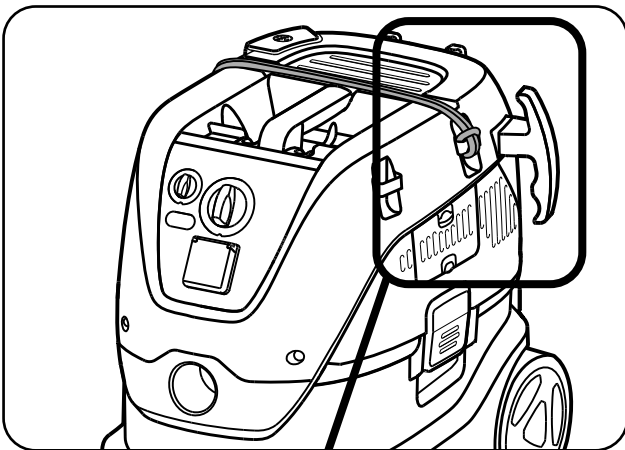
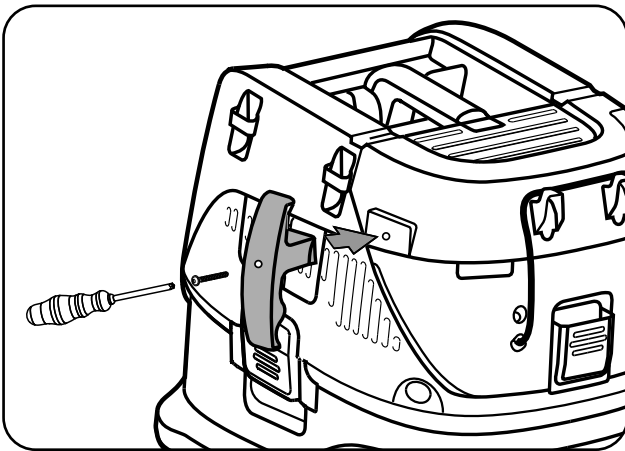
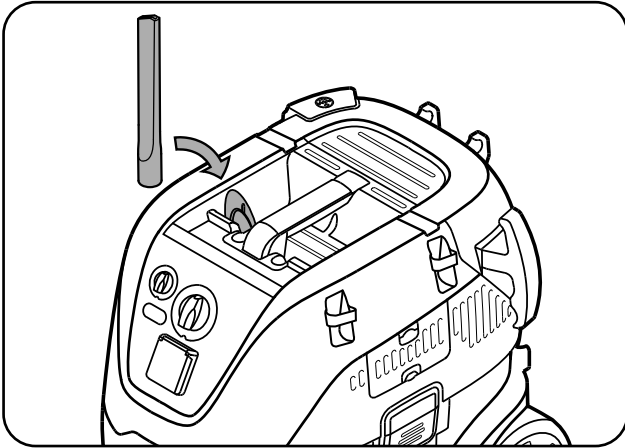

1

2

6A¹⁾

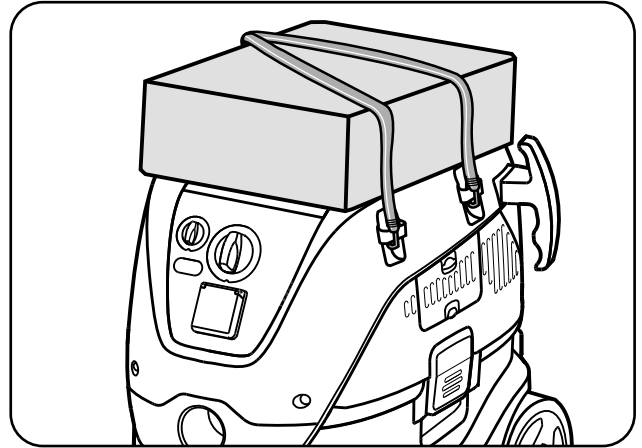

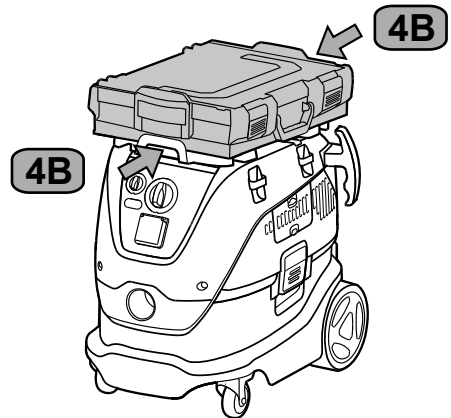
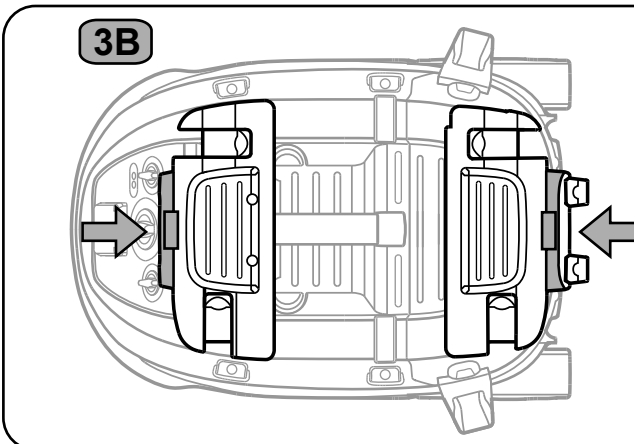
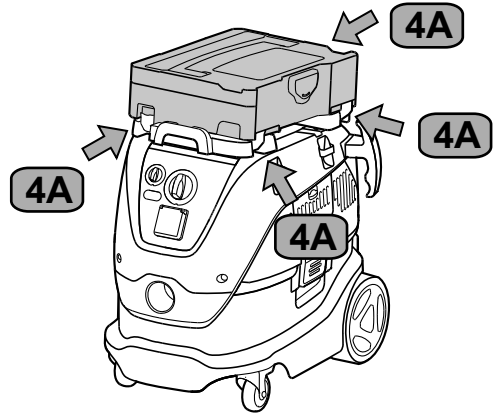
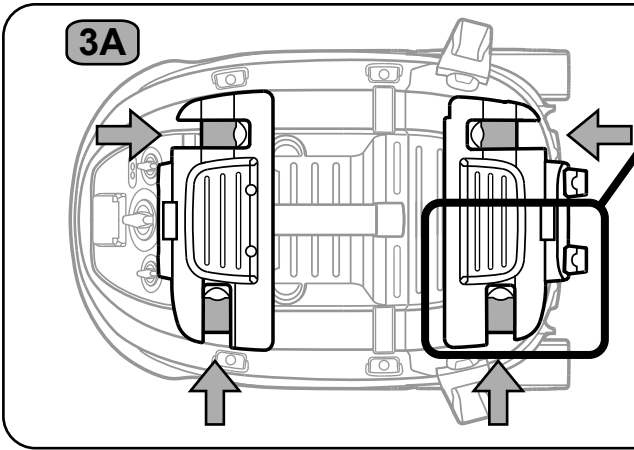
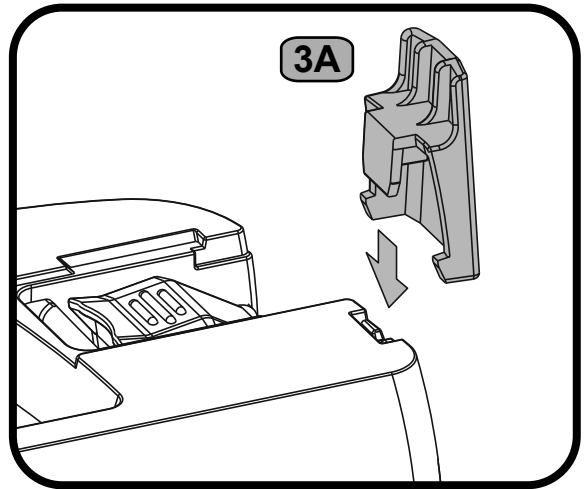
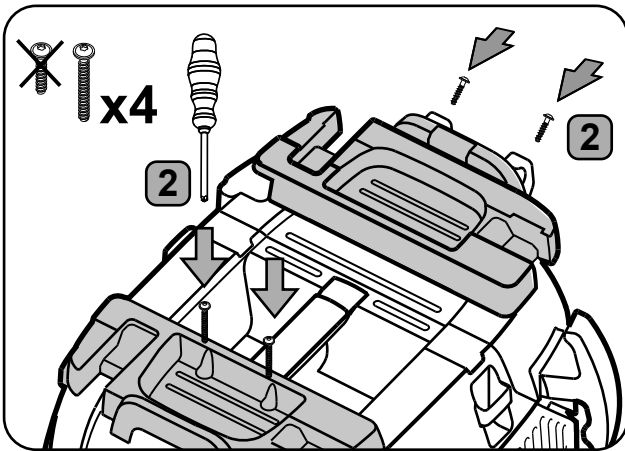
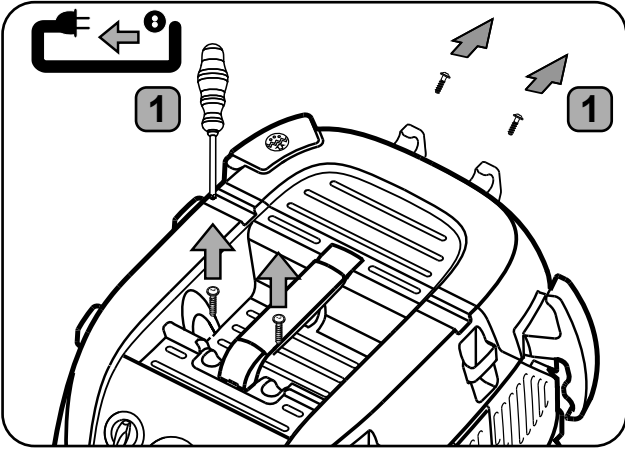

8A¹⁾

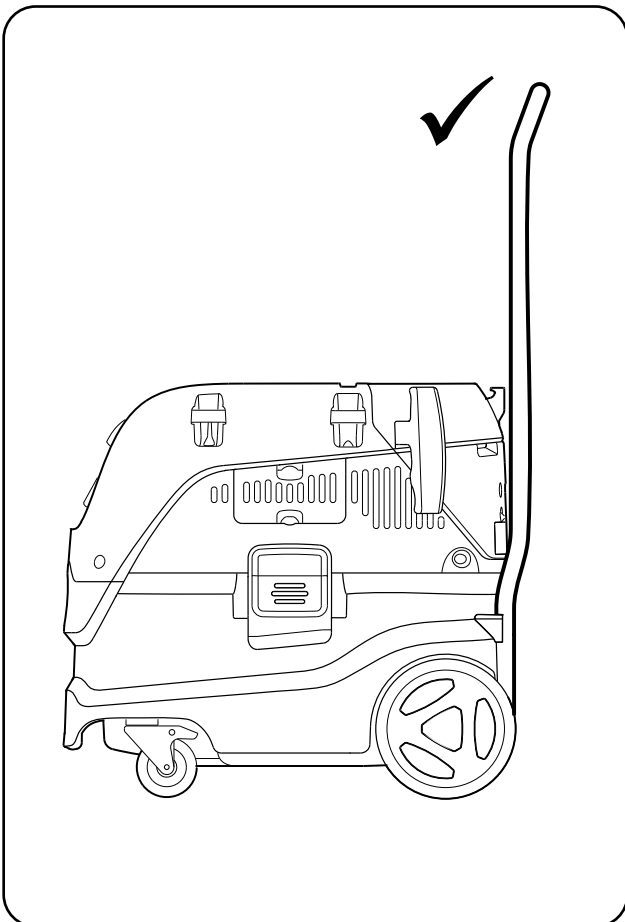
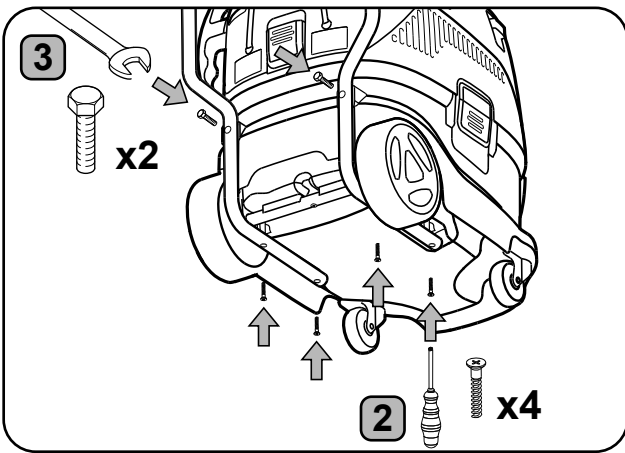
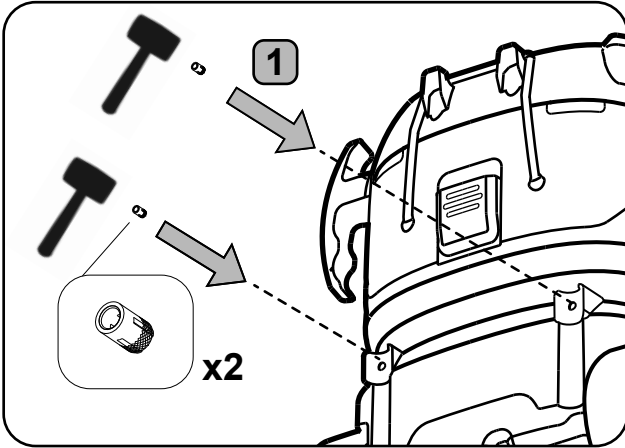

1B¹⁾

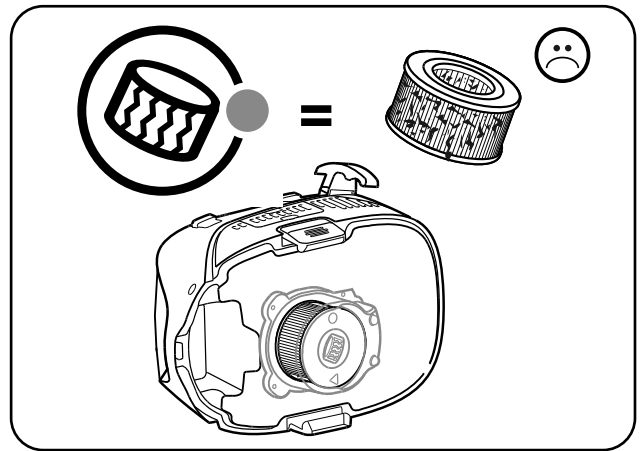
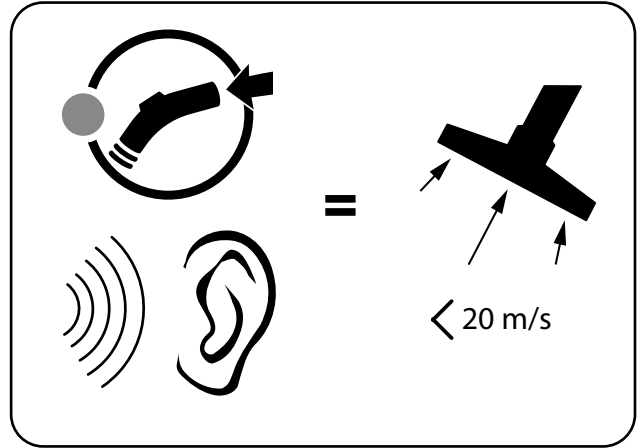

2B¹⁾

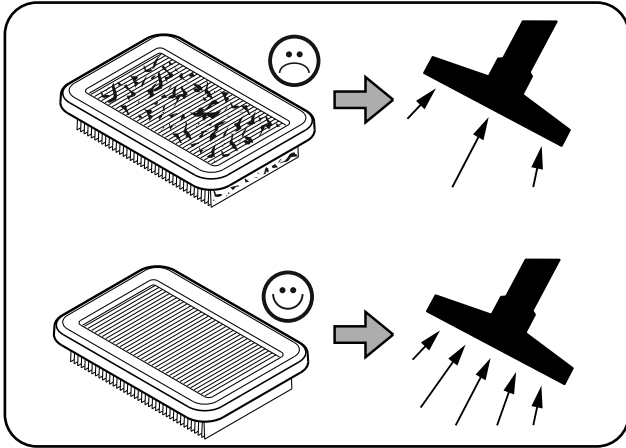

3B¹⁾

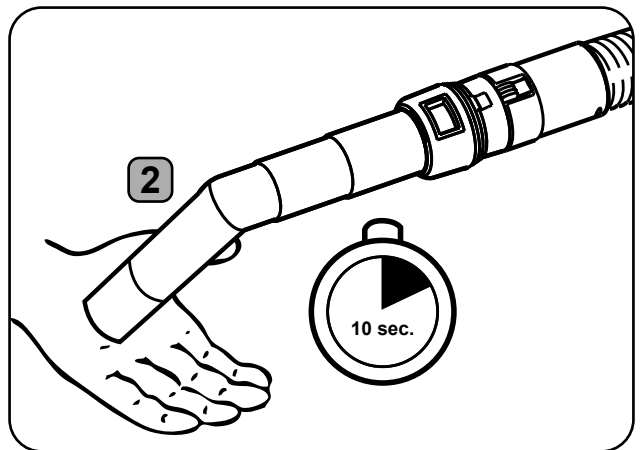
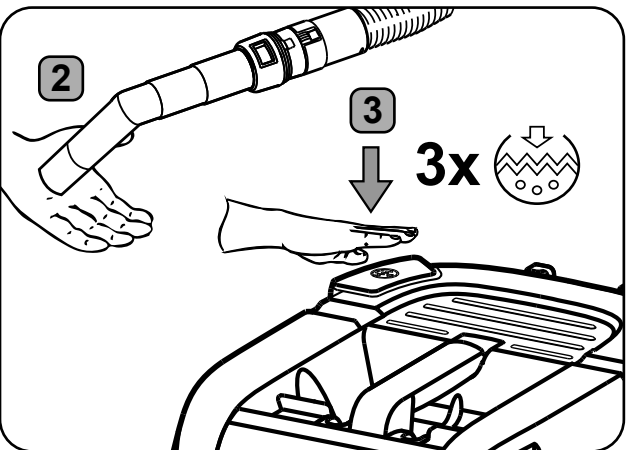
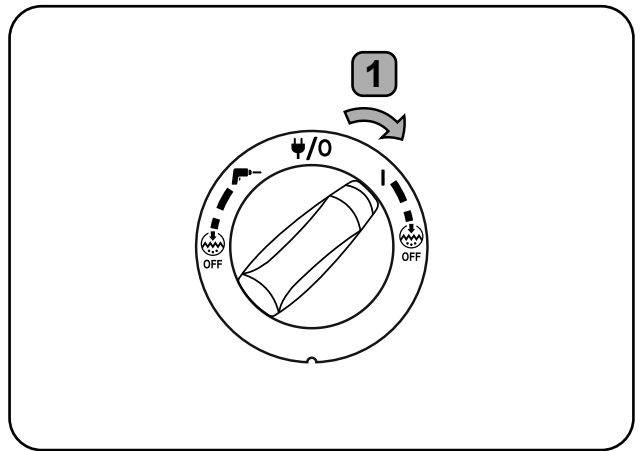
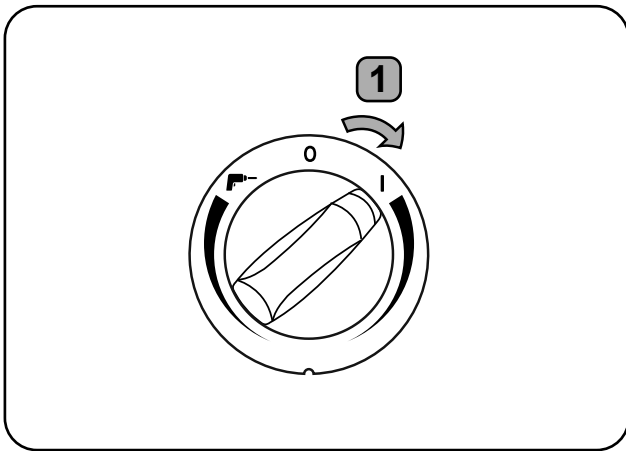
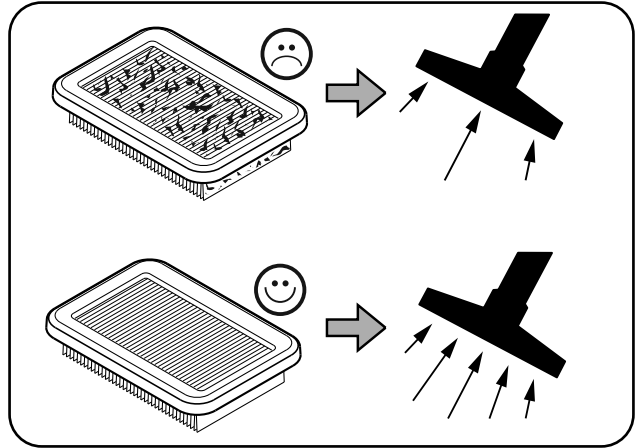

Push&Clean

InfiniClean

4B

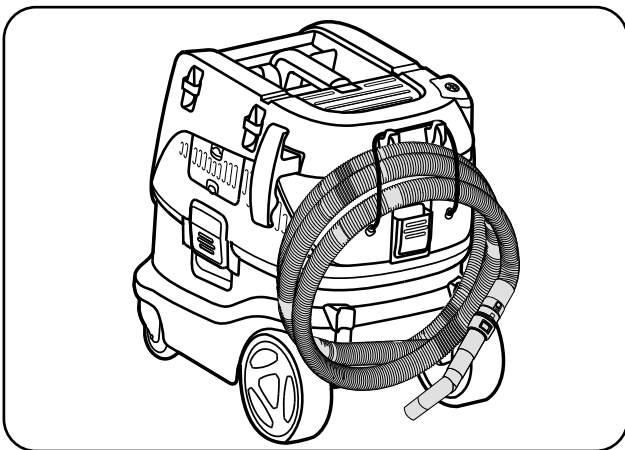
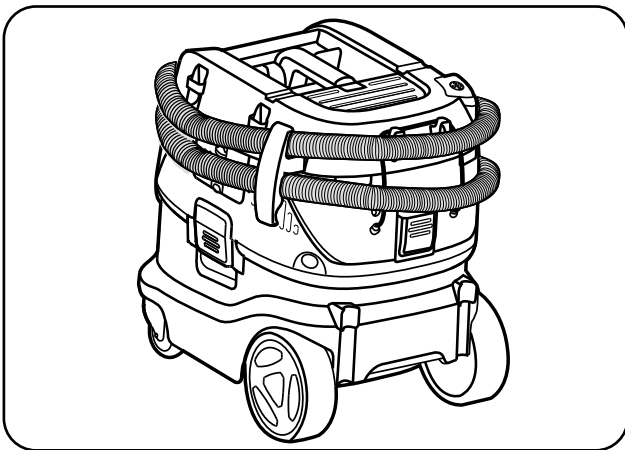
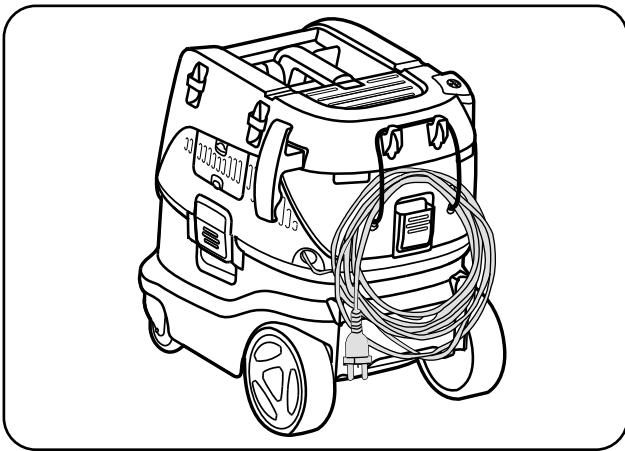
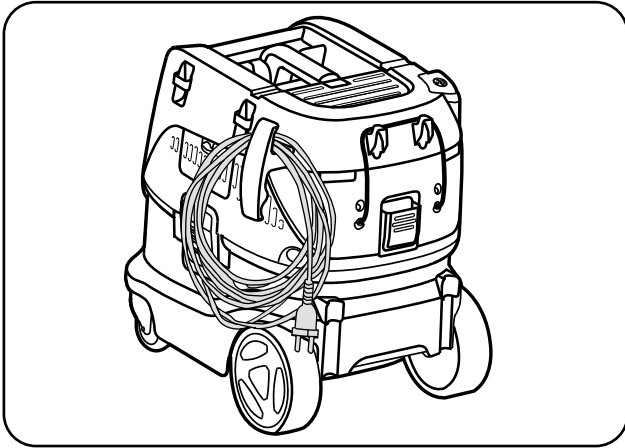

1C

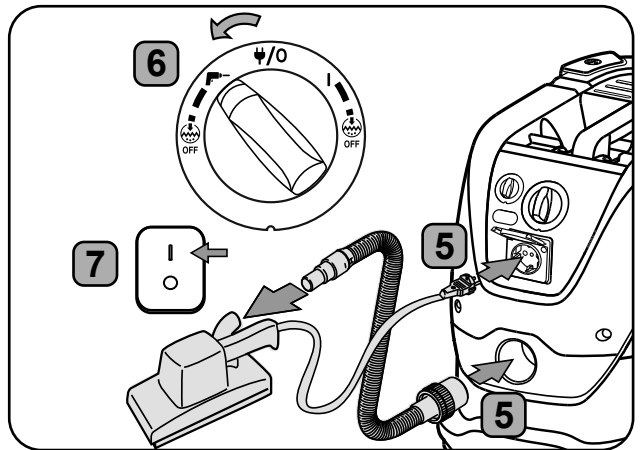
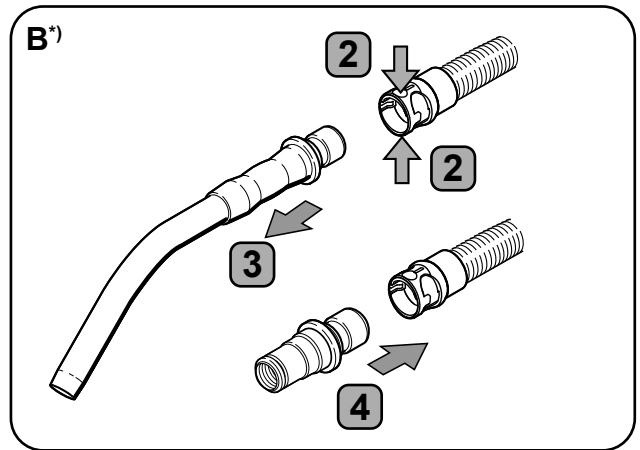
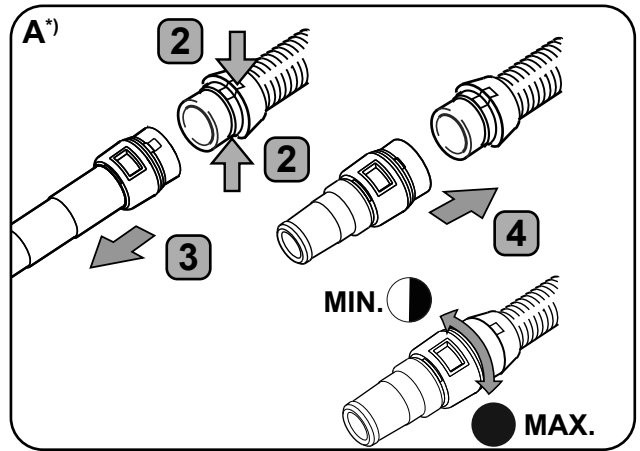
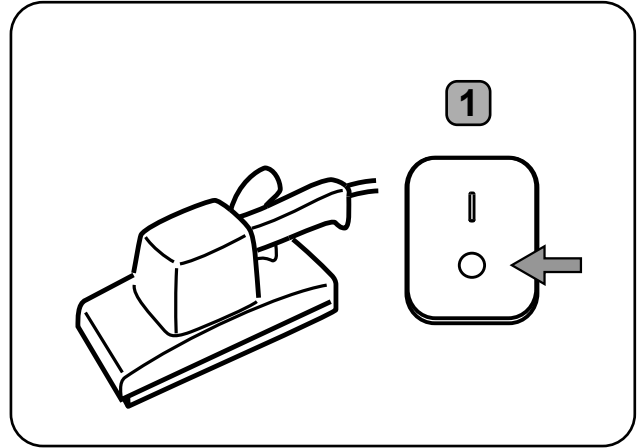

1D



2D¹⁾

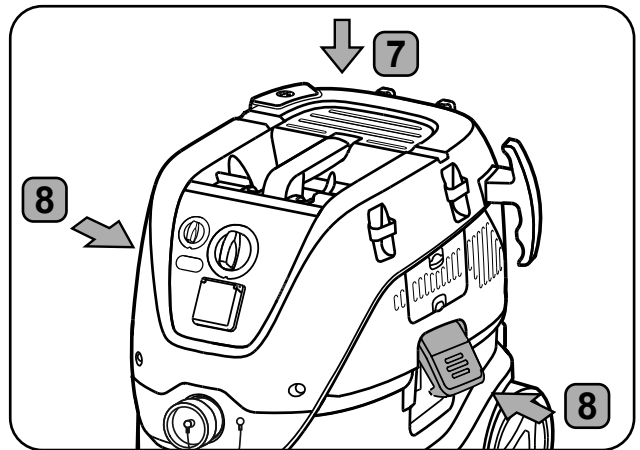
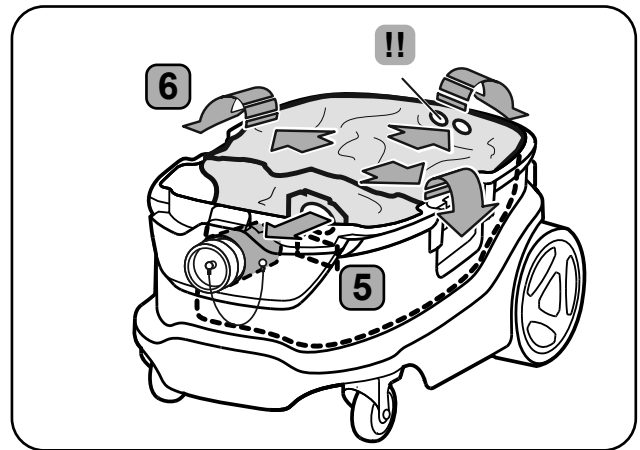
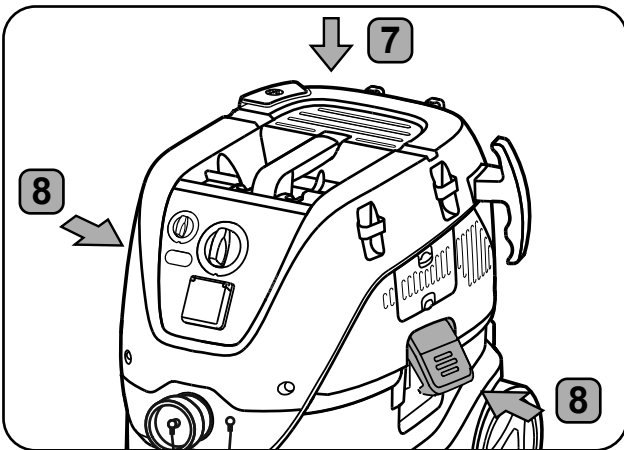
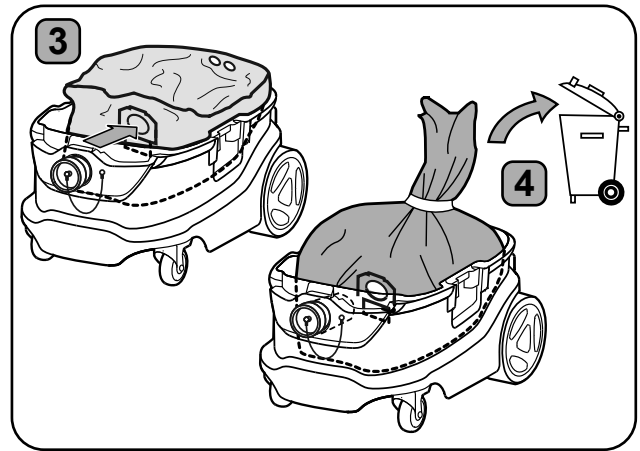
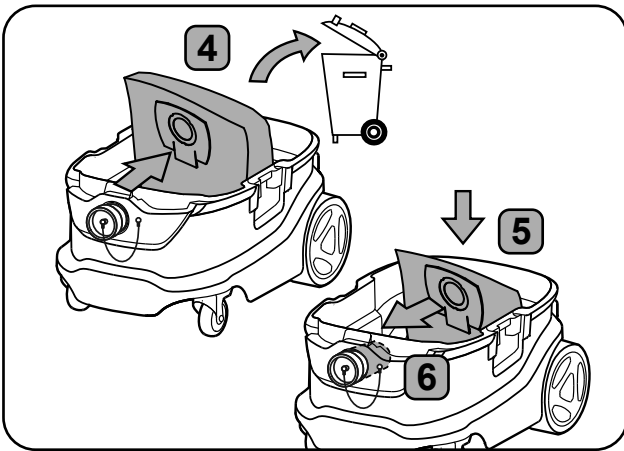
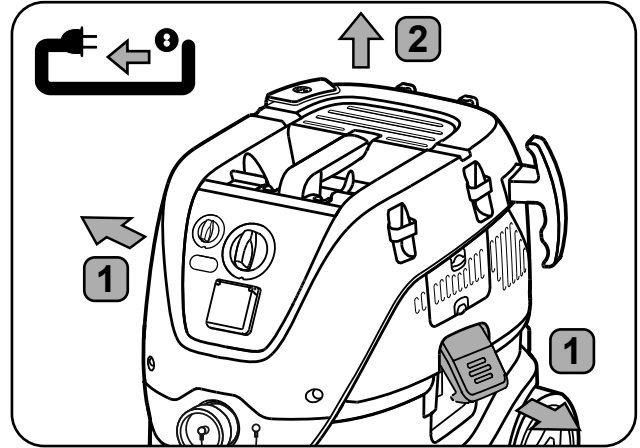
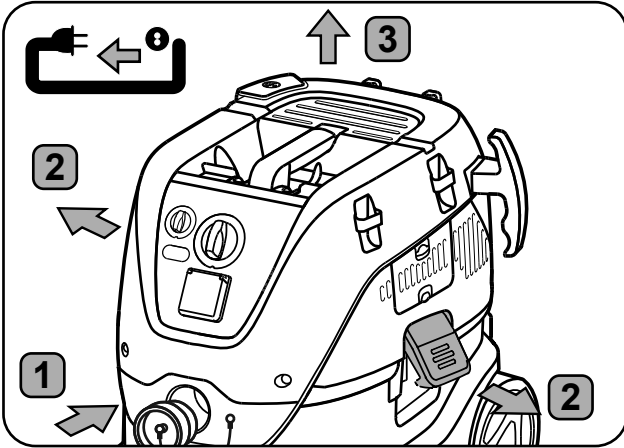



3D



4D

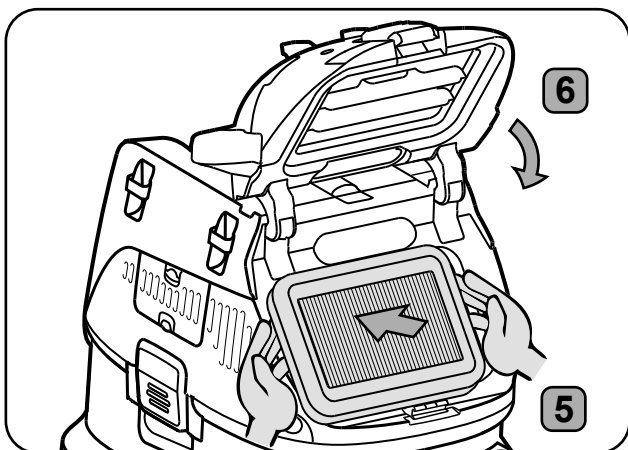
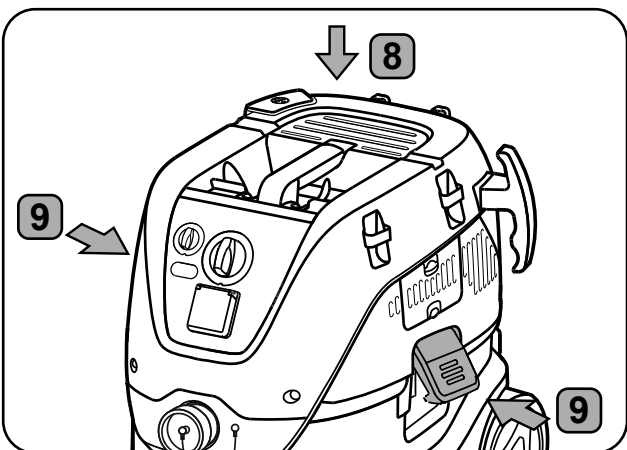
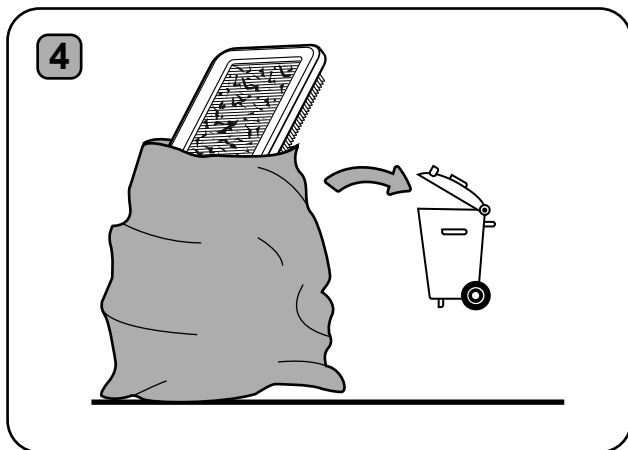
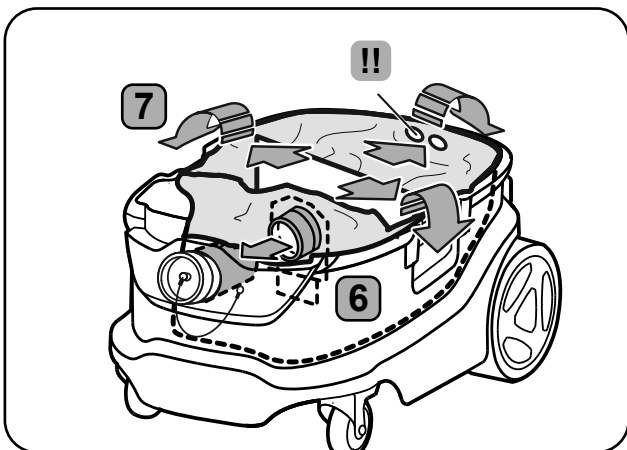
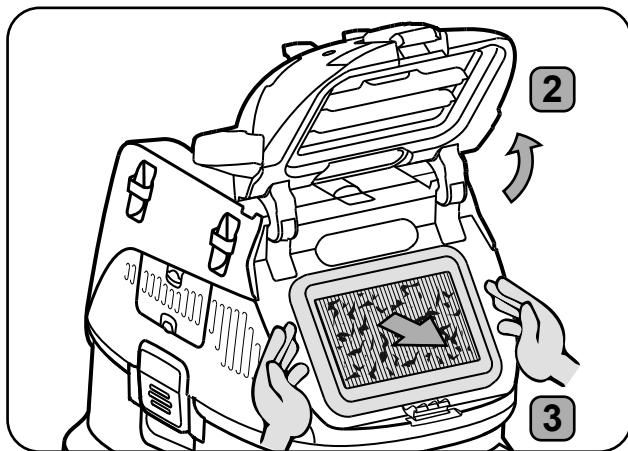
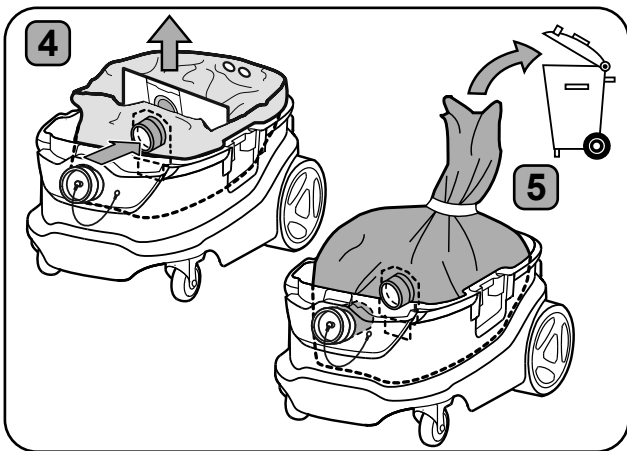
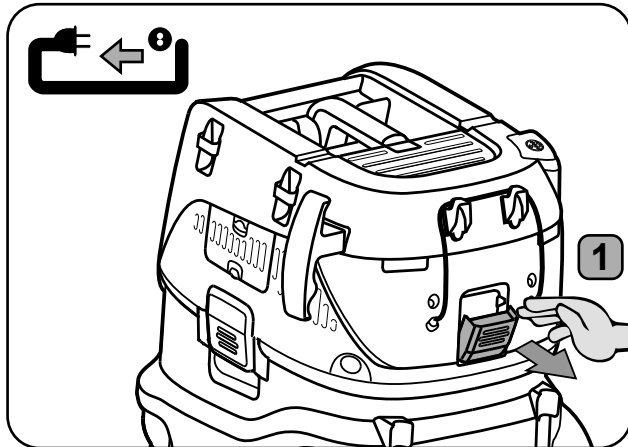
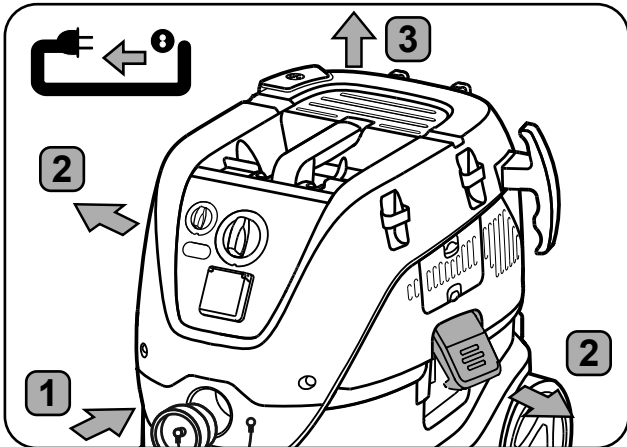
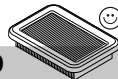

4D

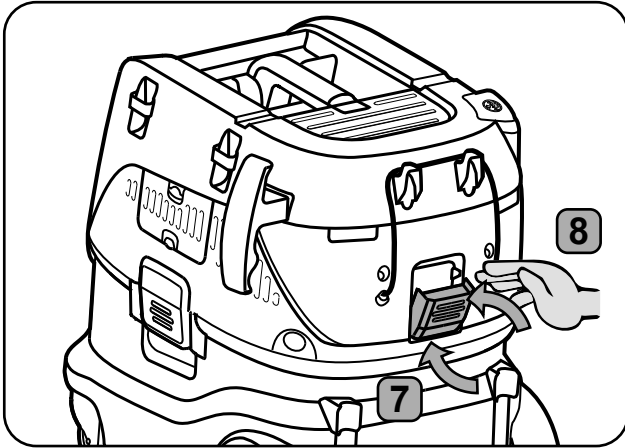

5D

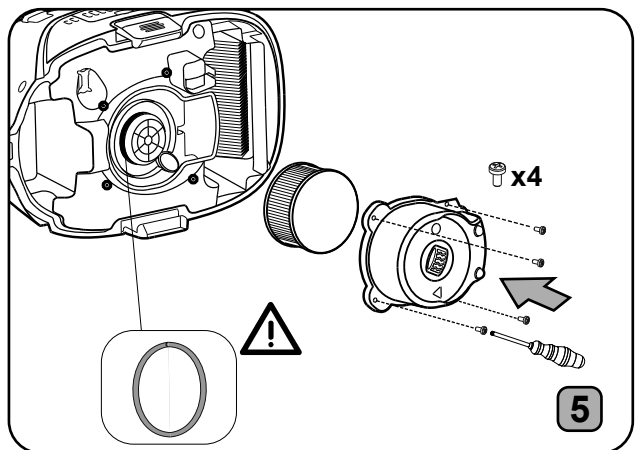
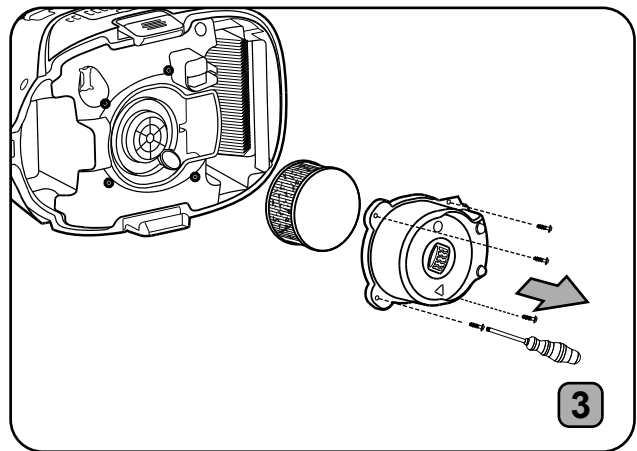
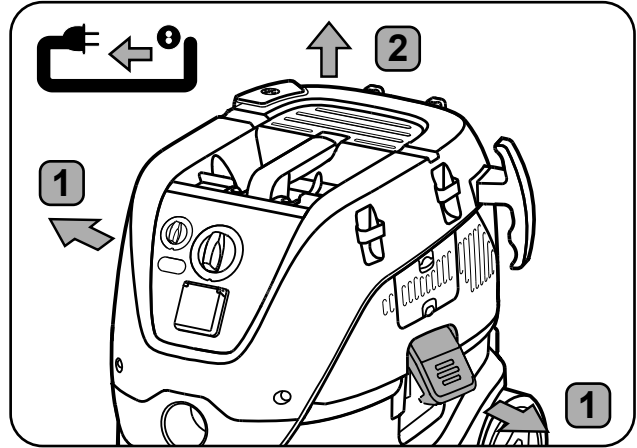

6D

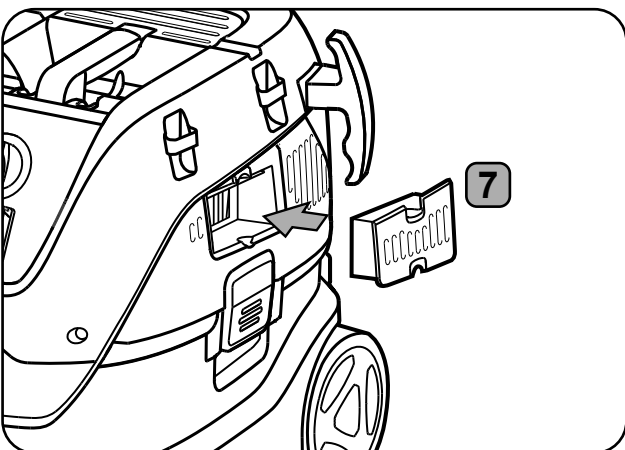
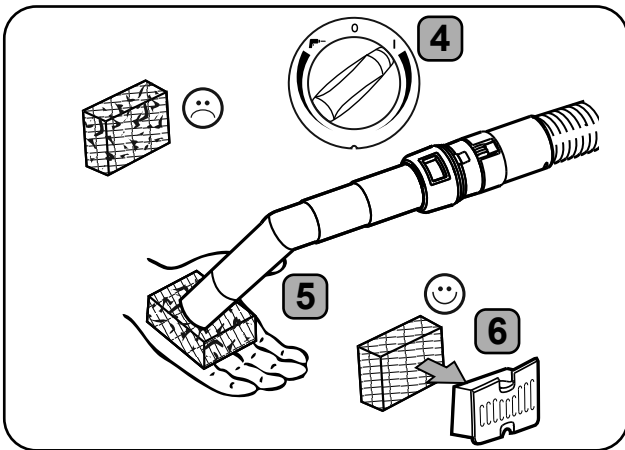
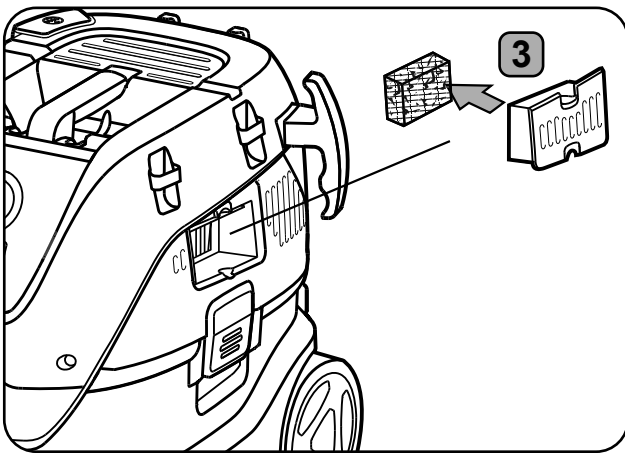
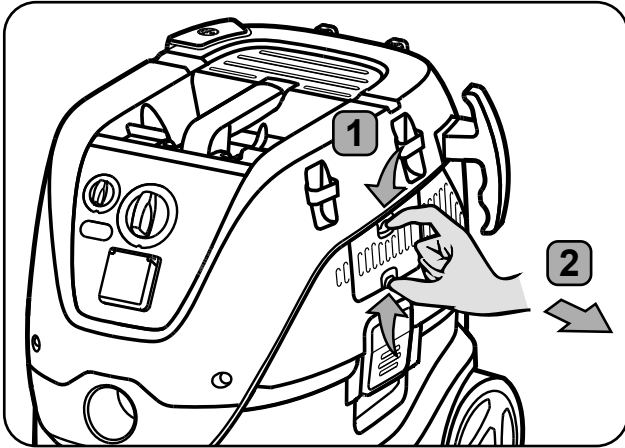

7D

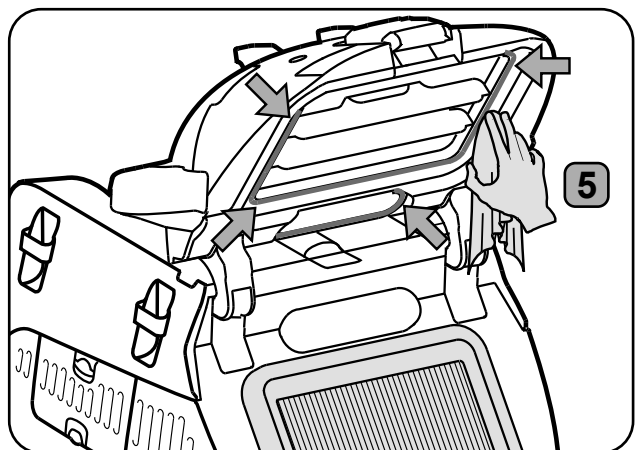
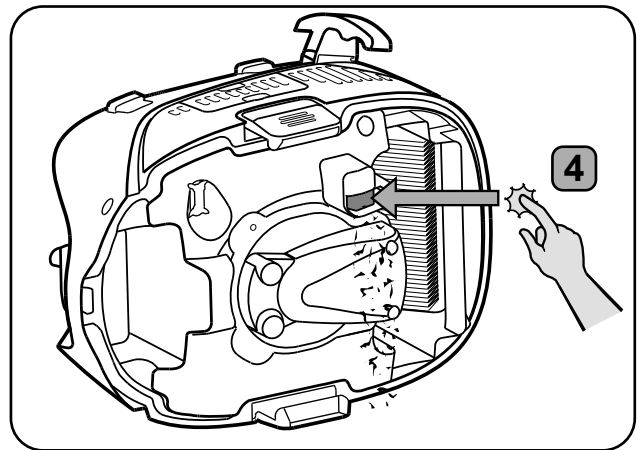
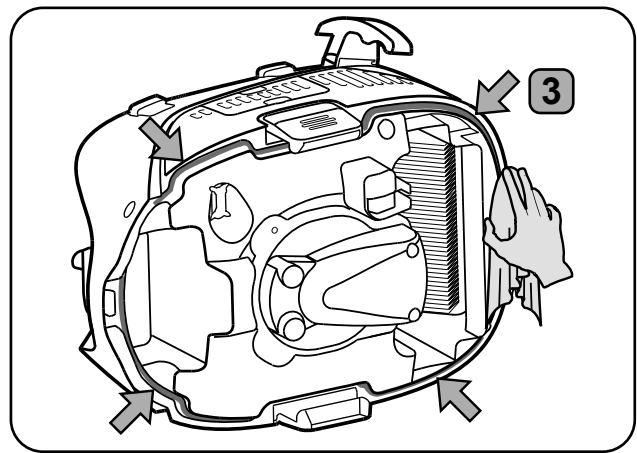
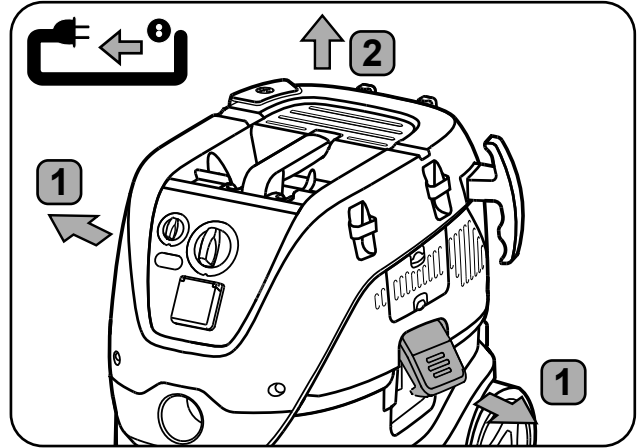

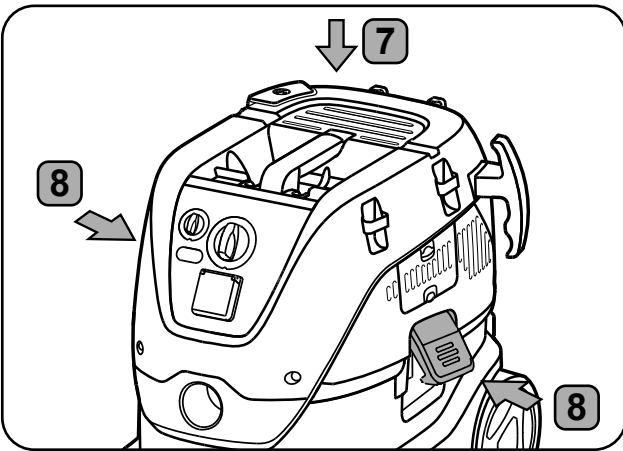
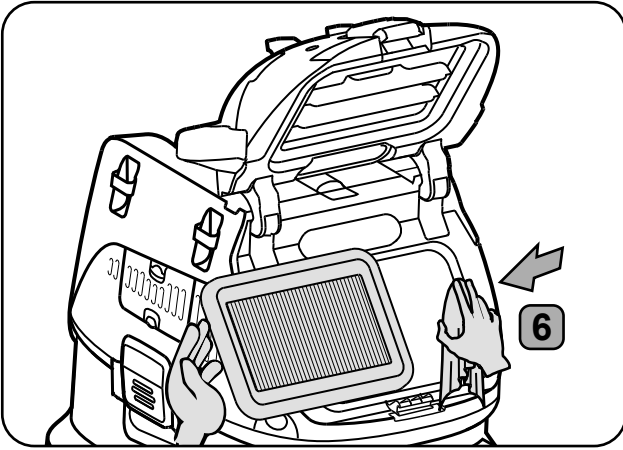
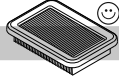

Quick reference guide

Operating elements:

1. Handle
2. Accessory positions
3. Latch
4. Castor
5. Container
6. Inlet fitting
7. Switch
8. Speed control*)
9. Appliance socket*)
10. Filter cleaning button (Push&Clean)*)
11. Hose hook
12. Hose diameter setting*)
13. LED indicator
14. Inlet cap

The pictorial quick reference guide

The pictorial quick reference guide is designed for helping you when starting up, operating and storing the unit. The guide are subdivided into 4 sections, which are represented by symbols:

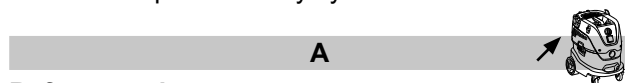

Before starting

DO READ OPERATING INSTRUCTIONS BEFORE USE!

- 1A - Unpack accessories
- 2A - Filter bag installation
- 3A - Disposal bag installation
- 4A - Safety filter bag installation
- 5A - Hose insert & operations
- 6A - Accessories placement
- 7A - Adaptor plate installation
- 8A - Trolley handle installation

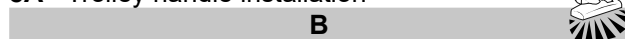

Control/Operation

- 1B - Flow rate and filter warning
- 2B - Push&Clean filter cleaning system
- 3B - InfiniClean filter cleaning system
- 4B - Cable and hose storage

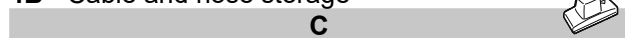

Connecting electrical appliances

- 1C - Power tool adaption

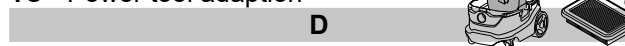

Maintenance:

- 1D - Filter bag replacement
- 2D - Disposal bag replacement
- 3D - Safety filter bag replacement
- 4D - Filter replacement Dust Class M & H
- 5D - Essential filter replacement Dust Class H
- 6D - Motor cooling air diffuser cleaning
- 7D - Gaskets and floater cleaning

Contents

1 Safety instructions	2
1.1 Symbols used to mark instructions	2
1.2 Instructions for use	2
1.3 Purpose and intended use	2
1.4 Electrical connection	3
1.5 Extension lead	3
1.6 Guarantee	3
1.7 Important warnings	3
2 Risks	4
2.1 Electrical components	4
2.2 Hazardous dust	5
2.3 Spare parts and accessories	6
2.4 In explosive or inflammable atmosphere ...	6
3 Control / Operation	6
3.1 Starting and operating of the machine	6
3.2 Auto-On/Off socket outlet for power tools ¹⁾	6
3.3 Push&Clean ¹⁾	7
3.4 InfiniClean ¹⁾	7
3.5 Flow rate warning	7
3.6 Antistatic connection ¹⁾	7
3.7 Cooling air filter	7
3.8 Wet pick-up	7
3.9 Dry pick-up	8
4 After using the machine	8
4.1 After use	8
4.2 Transport	8
4.3 Storage	8
4.4 Accessory and tool storage	8
4.5 Recycling the machine	8
5 Maintenance	9
5.1 Regular servicing and inspection	9
5.2 Maintenance	9
6 Further information	9
6.1 Specifications	10

¹⁾OEL=Occupational Exposure Limit, ¹⁾Optional accessories / Option depending on model
Original instruction

1 Safety instructions



This document contains the safety information relevant for the appliance along with a quick reference guide. Before starting up your machine for the first time, this instruction manual must be read through carefully. Save the instructions for later use.

Further support

Further information on the appliance can be found on our web site at www.Nilfisk.com.

For further queries, please contact the Nilfisk service representative responsible for your country. See reverse of this document.

1.1 Symbols used to mark instructions

DANGER



Danger that leads directly to serious or irreversible injuries, or even death.

WARNING



Danger that can lead to serious injuries or even death.

CAUTION



Danger that can lead to minor injuries and damage.

1.2 Instructions for use

The appliance must:

- only be used by persons, who have been instructed in its correct usage and explicitly commissioned with the task of operating it
- only be operated under supervision
- This appliance is not intended for use by persons (including children) with reduced physical, sensory or mental capabilities, or lack of experience and knowledge.
- Children shall be supervised to make sure that they do not play with the appliance.
- Do not use any unsafe work techniques.
- Never use the appliance without a filter.
- Switch off the appliance and disconnect the mains plug in the following situations:
 - Prior to cleaning and servicing
 - Prior to replacing components
 - Prior to changing over the appliance
 - If foam develops or liquid emerges

Besides the operating instructions and the binding accident prevention regulations valid in the country of use, observe recognised regulations for safety and proper use.

Before starting work, the operating staff must be informed on and trained within:

- use of the machine
- risks associated with the material to be picked up
- safe disposal of the picked up material

1.3 Purpose and intended use

This mobile dust extractor is designed, developed and rigorously tested to function efficiently and safely when properly maintained and used in accordance with the following instructions.

This machine is intended for commercial use, for example in hotels, schools, hospitals, factories, shops, offices and rental businesses.

This machine is also suitable for industrial use, such as e.g. plants, construction sites and workshops. Accidents due to misuse can only be prevented by those using the machine.

READ AND FOLLOW ALL SAFETY INSTRUCTIONS.

Any other use is considered as improper use. The manufacturer accepts no liability for any damage resulting from such use. The risk for such use is borne solely by the user. Proper use also includes proper operation, servicing and repairs as specified by the manufacturer.

The air flow in Safety Vacuum systems has to be strictly controlled to achieve a minimum flow rate of $V_{\min} = 20$ m/s in the suction hose.

For **Dust Class H** machines (with type designation -0H, -2H) following applies:

The appliance is suitable for picking up dry, non-flammable dust, non flammable liquids, hazardous dusts with OEL¹⁾ values, carcinogenic dusts, dusts containing germs.

Dust Class H machines (with type designation -0H, -2H) are also approved for asbestos abatement according to TRGS 519.



Dust Class H (IEC 60335-2-69).

The dusts which belong to this class are: dusts with OEL values¹⁾, all carcinogenic dusts and dusts which are mixed with pathogenic agents. Vacuums for Dust Class H are tested in their entirety and have a maximum degree of permeability of 0.005%. The disposal must be dust free.

The safety label on the machine warns:

This appliance contains dust hazardous to health. Emptying and maintenance operations, including removal of the dust collecting means, must only be carried out by authorised personnel wearing suitable personal protection. Operate only after the full filtration system has been fitted and checked.

For dust extractors, ensure adequate air change rate H, when the exhaust air is returned to the room. Observe national regulations before use.

For **Dust Class M** machines (with type designation -2M) following applies:

The appliance is suitable for picking up dry, non-flammable dust, non flammable liquids, sawdust and hazardous dusts with OEL¹⁾ values $\geq 0.1 \text{ mg/m}^3$



Dust Class M (IEC 60335-2-69). The dusts which belong to this class are: dusts with OEL values¹⁾

$\geq 0.1 \text{ mg/m}^3$ as well as saw dust. The machine is tested in its entirety by vacuums for this dust class. The maximum degree of permeability is 0.1% and the disposal must be low dust.

For dust extractors, ensure adequate air change rate M, when the exhaust air is returned to the room. Observe national regulations before use.

1.4 Electrical connection

- It is recommended that the machine should be connected via a residual current circuit breaker.
- Arrange the electrical parts (sockets, plugs and couplings) and lay down the extension lead so that the protection class is maintained.
- Connectors and couplings of power supply cords and extension leads must be watertight.

1.5 Extension lead

1. As an extension lead, only use the version specified by the manufacturer or one of a higher quality.
2. When using an extension lead, check the minimum cross-sections of the cable:

Cable length	Cross section	
	< 16 A	< 25 A
up to 20 m	1.5 mm ²	2.5 mm ²
20 to 50 m	2.5 mm ²	4.0 mm ²

1.6 Guarantee

Our general conditions of business are applicable with regard to the guarantee.

Unauthorised modifications to the appliance, the use of incorrect brushes in addition to using the appliance in a way other than for the intended purpose exempt the manufacturer from any liability for the resulting damage.

1.7 Important warnings

WARNING



- To reduce the risk of fire, electric shock, or injury, please read and follow all safety instructions and caution markings before use. This machine is designed to be safe when used for

cleaning functions as specified. Should damage occur to electrical or mechanical parts, the machine and / or accessory should be repaired by a competent service center or the manufacturer before use in order to avoid further damage to the machine or physical injury to the user.

- Do not leave the machine when it is plugged in. Unplug from the socket when not in use and before maintenance.
- Outdoor use of the appliance shall be limited to occasional use.
- Do not use with damaged cord or plug. To unplug grasp the plug, not the cord. Do not handle plug or machine with wet hands. Turn off all controls before unplugging.
- Do not pull or carry by cord, use cord as a handle, close a door on cord, or pull cord around sharp edges or corners. Do not run machine over cord. Keep cord away from heated surfaces.
- Keep hair, loose clothing, fingers and all parts

¹⁾OEL=Occupational Exposure Limit, ²⁾ Optional accessories / Option depending on model
Original instruction

of the body away from openings and moving parts. Do not put any objects into openings or use with opening blocked. Keep openings free of dust, lint, hair, and anything else that could reduce the flow of air.

- Do not use in outside areas at low temperature.
- Do not use to pick up flammable or combustible liquids such as gasoline, or use in areas where they may be present.
- Do not pick up anything that is burning or smoking, such as cigarettes, matches or hot ashes.
- Use extra care when cleaning on stairs.
- Do not use unless filters are fitted.
- If the machine is not working properly or has been dropped, damaged, left outdoors, or dropped into water, return it to a service center or dealer.
- If foam or liquid escapes from the machine, switch off immediately.
- The machine may not be used as a water pump. The machine is intended

for vacuuming air and water mixtures.

- Connect the machine to a properly earthed mains supply. The socket outlet and the extension cable must have an operative protective conductor.
- Provide for good ventilation at the working place.
- Do not use the machine as a ladder or step ladder. The machine can tip over and become damaged. Danger of injury.
- Only use the socket outlet on the machine for purposes specified in the instructions.

2 Risks

2.1 Electrical components

DANGER



The upper section of the machine contains live components.

Contact with live components leads to serious or even fatal injuries.

Never spray water on to the upper section of the machine.

DANGER



Electric shock due to faulty mains connecting lead. Touching a faulty mains

connecting lead can result in serious or even fatal injuries.

- Do not damage the mains power lead (e.g. by driving over it, pulling or crushing it).
- Regularly check whether the power cord is damaged or shows signs of ageing.
- If the electric cable is damaged, it must be replaced by an authorized Nilfisk distributor or similar qualified person in order to avoid a hazard.
- In no circumstances should the power supply cord be wrapped around fingers or any part of the operators person.

2.2 Hazardous dust

WARNING



Hazardous materials. Vacuuming up hazardous materials can lead to serious or even fatal injuries. The following materials must not be picked up by the machine:

- hot materials (burning cigarettes, hot ash, etc.)
- flammable, explosive, aggressive liquids (e.g. petrol, solvents, acids, alkalis, etc.)

- flammable, explosive dust (e.g. magnesium or aluminium dust, etc.)

WARNING



Using the appliance for asbestos abatement work according to German regulation TRGS 519. To pick up materials containing asbestos:

- Dust Class H machines (with type designation -0H, -2H) can be used for picking up asbestos.
- Use a suction hose with a maximum diameter of 36 mm.

Use the closable plastic sack to ensure dust-free transport of the appliance and contaminated parts (hose, hand pipe, nozzles, etc.). Once the asbestos appliance has been used in an exclusion area as defined in TRGS 519, it should no longer be used in so-called "white" areas. Exceptions are only permitted if the asbestos cleaner has previously been completely decontaminated by a specialist as specified in TRGS 519 No. 2.7 (e.g. not only the outer case but also, for example, the cooling air rooms, the installation rooms for electrical supplies, the supplies themselves, etc.). A written report must be made by a specialist and signed by him.

When picking up materials containing asbestos the exhaust air must not be returned into the room. Use the exhaust air socket and a hose with a length of maximum 4 m and a nominal diameter of minimum 50 mm.



2.3 Spare parts and accessories

CAUTION



Spare parts and accessories. The use of non-genuine spare parts, brushes and accessories can impair the safety and or function of the appliance.

Only use original spare parts and accessories from Nilfisk. Spare parts that can affect health and safety of the operator and or function of the appliance, are specified below:

Description	Order No.
Flat filter PTFE M Class, 1 pcs. 	107413540
Dust Class H filter, 1 pcs 	107413555
Fleece filter bag, 5 pcs.	107419593
Disposal bag, 5 pcs.	107417821
Safety filter bag, 5 pcs.	107413549
Motor cooling air filter PET, 1 pcs.	107413541

2.4 In explosive or inflammable atmosphere

CAUTION



This machine is not suitable for use in explosive or inflammable atmospheres or where such atmospheres are likely to be produced by the presence of volatile liquid or inflammable gas or vapour.

3 Control / Operation

CAUTION



Damage due to unsuitable mains voltage. The appliance can be damaged as a result of being connected to an unsuitable mains voltage.

- Ensure that the voltage shown on the rating plate corresponds to the voltage of the local mains power supply.

3.1 Starting and operating of the machine

Check that the electrical switch is switched off (in position 0). Check that suitable filters are installed in the machine. Then connect the suction hose into

the suction inlet at the machine by pushing the hose forward until it fits firmly in place at the inlet. Then connect the tubes with the hose handle, twist the tubes in order to ensure that they are properly fitted. Attach suitable nozzle to the tube. Choose nozzle depending on what type of material that is to be picked-up. If used for dust extraction in connection with dust producing tool then connect end of suction hose with appropriate adapter. Check that hose diameter setting corresponds to actual hose diameter. Connect the plug into a proper electrical outlet. Put the electrical switch into position I in order to start the motor.

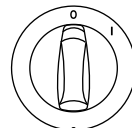



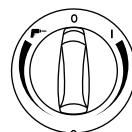

Turn I: Activate the machine
Turn 0: Stop the machine

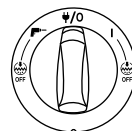

Turn I: Activate the machine – turn clock wise for speed control
Turn 0: Stop the machine
Turn : Activate Auto-On/Off operation – turn counterclockwise for speed control



Turn I: Activate the machine
Turn /0: Stop the machine. Permanent power on socket.
Turn : Activate Auto-On/Off operation.
Turn I+  Off: Activate the machine with deactivated automatic filter cleaning function
Turn  +  Off: Activate Auto-On/Off operation with deactivated automatic filter cleaning function.
Speed control operation on separate turning knob

The hose diameter and the setting for suction hose diameter must be the same.

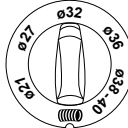
	
ø21	ø21
ø27	ø27
ø32	ø32
ø36	ø36
ø38-40	ø38-40

3.2 Auto-On/Off socket outlet for power tools¹⁾

CAUTION



Appliance socket.* The appliance socket is designed for electrical auxiliary equipment; see technical data for reference.

- Prior to plugging in an appliance, always switch off the machine and the appliance that is to be connected.
- Read the operating instructions to the ap-

pliance to be connected and observe the safety notes contained in these.

An appliance socket with earthing contact is integrated in the machine. An external power tool can be connected there. The socket features permanent power on¹⁾, when the electrical switch is in position , i.e. the machine can be used as an extension cord.

In position  the machine can be switched on and off by the power tool connected. Dirt is picked up from the source of dust immediately. To comply with regulations, only approved dust producing tools should be connected.

The maximum power consumption of the connected electrical appliance is stated in section "Specifications".

Before turning the switch to position  ensure that the tool connected to the appliance socket is switched off.

3.3 Push&Clean²⁾

The "PC" machine is equipped with a semi automatic filter cleaning system, Push&Clean. The filter cleaning system must be actuated latest when the suction performance is no longer sufficient. Regular use of the filter cleaning feature maintains suction performance and increases the lifetime of the filter. For instruction see quick reference guide.

3.4 InfiniClean²⁾

The "IC" machine is equipped with an automatic filter cleaning system, InfiniClean. A frequent cleaning cycle will automatically run during operation to ensure that suction performance is always at its best.

If suction performance decreases or in extensive dust applications a manually filter cleaning operation is recommended:

- Switch off the machine
- Close the nozzles or suction hose opening with the palm of your hand.
- Turn the switch to position „I“ and let the machine operate at full speed for approx. 10 seconds with the suction hose opening closed.

If suction power is still reduced take out the filter and clean mechanically or replace filter.

For certain applications, like wet pick up, it is recommended to turn off the automatic filter cleaning system. For details see chapter 3.1.

3.5 Flow rate warning

CAUTION



Check that all the filters are present and properly fitted.

The machine is equipped with a system to monitor air velocity and Dust Class H filter

condition³⁾. Before picking up dust with occupational exposure limit values, check the volume flow monitor.

When the motor is running, hold the suction hose shut to reduce the volume flow. The LED indicator on front panel will light after approx. 1 second. The acoustic warning sounds after some additional seconds.

Set the diameter setting to the actual hose size.



When LED indicator lights, air velocity is below 20 m/s.

- check if container or filter bag is full.
- check if air flow is reduced in suction hose, tube/nozzle, filter.



When LED indicator lights, Dust Class H or HEPA filter is missing, damaged or clogged. The filter needs to be installed or replaced to obtain needed air flow.

3.6 Antistatic connection²⁾

CAUTION



The machine is equipped with an antistatic system to discharge any static electricity that may develop during dust pick-up.

The antistatic system is placed in front part of the motor top and creates an earth ground connection to the inlet fitting of the container. For proper function the use of an electrical conductive or antistatic suction hose is recommended. When inserting the optional disposal bag make sure the antistatic connection is kept.

3.7 Cooling air filter

To protect the electronics and motor, the machine is equipped with a cooling air diffusor. Clean the cooling air diffusor regularly.

For areas with a high concentration of fine dust in the surrounding air it is recommended to equip the machine with an optional cooling air filter cartridge to prevent dust from settling inside the air channels and motor. Contact your local sales representative.

CAUTION



If cooling air filter is clogged by dust the overload protection switch in the motor can be activated. In such case switch off the machine, clean cooling air filter and allow machine to cool for approx. 5 minutes.

3.8 Wet pick-up

CAUTION



The machine is equipped with a water level limit system which shuts off the machine when the maximum liquid level is reached.

When this occurs, switch off the machine. Disconnect the machine from the socket and empty the container. Never pick up liquids without the water level limit system and filter in place.

Picking up liquids.

- Do not pick up flammable liquids
- Before liquids are picked up, always remove the filter bag/wastebag and check that the water level limit works properly.
- If foam appears, stop work immediately and empty the tank.
- Clean the water level limiting device regularly and check for signs of damage.

Before emptying the container, unplug the machine. Disconnect the hose from the inlet by pulling out the hose. Release the latch by pulling them outwards so that the motor top is released. Lift up the motor top from container. Always empty and clean the container and water level limit system after picking-up liquids.

Empty by tilting the container backwards or sideways and pour the liquids into a floor drain or similar. Put back the motor top to the container. Secure the motor top with the latches.

Heavy maneuvers can, by mistake, trigger the water level limiting device. Should this happen; turn off the machine and wait for 3 seconds to reset the device. Continue to operate the machine afterwards.

3.9 Dry pick-up

CAUTION



Picking up environmentally hazardous materials.

Materials picked up can present a hazard to the environment.

- Dispose of the dirt in accordance with legal regulations.

CAUTION¹⁾



Dust Class H machines are equipped with an upstream Dust Class H filter fitted on bottom side of motor top under a guard cover.

Check that filter guard cover and sealing are safety installed and without damage and that the filter is properly fitted.

A LED indicator will light if the filter needs to be replaced, or if the filter is missing, mounted incorrectly or damaged.

Remove the electrical plug from the socket before emptying after dry pick-up. Remove the suction hose from the machine and close the inlet cap, to avoid harmful dust spreading. Release the latch by pulling them outwards so that the motor top is released. Lift up the motor top from container.

Main Filter: check the filter. To clean the filter you can either brush or wash it. Wait until the filter is dry before re-starting dust pick-up.

Essential Filter Dust Class H: check the filter. Replace filter if necessary. Wear mask and protective clothing.

Dustbag: check bag to ensure the fill factor. Replace dust bag if necessary. Remove the old bag.

The new bag is fitted by passing the cardboard piece with the rubber membrane through the vacuum inlet. Make sure that the rubber membrane is passing past the heightening at the vacuum inlet.

Safety filter bag: check bag to ensure the fill factor. Replace dust bag if necessary. Wear mask and protective clothing when removing the old bag. Carefully remove the dust bag connection from the inlet fitting. Close the dust bag connection with the slide. Dispose of the dirt in accordance with legal regulations.

After emptying: close motor top to the container and secure the motor top with the latches. Never pick up dry material without filter fitted in the machine. The suction efficiency of the machine depends on the size and quality of the filter and dust bag. Therefore - use only Original filter and dust bags.

4 After using the machine

4.1 After use

After picking up hazardous dust, close the inlet cap and clean the outside of the machine.

Remove the plug from the socket when machine is not in use. Wind up the cord starting from the machine. The power cord can be wound up around the motor top or at the container or placed in the included hook, or fastening means. Some variants have special storage places for accessories.

4.2 Transport

- Before transporting the machine, close all the latches.
- Close the inlet with the inlet cap.
- Do not tilt the machine if there are liquids in the dirt tank.
- Do not use a crane hook to lift the machine.
- Do not lift the machine by the trolley handle *)

4.3 Storage

CAUTION



Store the appliance in a dry place, protected from rain and frost. The machine shall be stored indoors only.

4.4 Accessory and tool storage

For convenient transport and storage of accessories or tools, integrated rails are found on side of machine which allows fastening with straps or other means. A flexible strap and hooks are included on back of machine for attachment of suction hose or mains cable. For instruction see quick reference guide.

An optional adapter plate²⁾ with attachment system can be installed on top of machine for fastening of 2-point or 4-point storage cases.

Remove the electrical plug from the socket before installing the adapter plate.

CAUTION¹⁾

Do not lift machine in adapter plate without having storage case safely installed. Note the weight and balance of the appliance in case of storage. Maximum weight of storage cases is 30 kg.

4.5 Recycling the machine

Make the old machine unusable.

1. Unplug the machine.
2. Cut the power cord.
3. Do not discard of electrical appliances with household waste.



As specified in European Directive 2012/19/EU on old electrical and electronic appliances, used electrical goods must be collected separately and recycled ecologically.

5 Maintenance**5.1 Regular servicing and inspection**

Regular servicing and inspection of your machine must be carried out by suitably qualified personnel in accordance with relevant legislation and regulations. In particular, electrical tests for earth continuity, insulation resistance, and condition of the flexible cord should be checked frequently.

In the event of any defect, the machine **MUST** be withdrawn from service, completely checked and repaired by an authorized service technician.

At least once a year, a Nilfisk technician or an instructed person must perform a technical inspection including filters, air tightness and control mechanisms. Appliances in Dust Class H must have their filtration efficiency checked once a year. The result must be presented upon request. If the efficiency of the filter does not fulfil the requirements for Dust Class H, the filter must be replaced.

5.2 Maintenance

Remove the plug from the socket before performing maintenance. Before using the machine make sure that the frequency and voltage shown on the rating plate correspond with the mains voltage.

The machine is designed for continuous heavy work. Depending on the number of running hours – the dust filter should be renewed. Keep the machine clean with a dry cloth, and a small amount of spray polish.

During maintenance and cleaning, handle the machine in such a manner that there is no danger for maintenance staff or other persons.

In the maintenance area

- Use filtered compulsory ventilation
- Wear protective clothing
- Clean the maintenance area so that no harmful substances get into the surroundings.

CAUTION

In the case of asbestos abatement wear additional single-use clothing. Wear a P2 breathing mask.

Before removing the machine from the area contaminated with harmful substances:

Clean the outside of the machine, wipe it clean or pack the machine in well sealed packaging and avoid spreading deposited harmful dust.

After use, in asbestos contaminated areas, the machine must be cleaned by an authorised person according to TRGS 519.

During maintenance and repair work all contaminated parts that could not be cleaned satisfactorily must be:

- Packed in well sealed bags
- Disposed of in a manner that complies with valid regulations for such waste removal.

For details of after sales service contact your dealer or Nilfisk service representative responsible for your country. See reverse of this document.

6 Further Informationen

6.1 Specifications

		ATTIX 33 M/H, ATTIX 44 M/H													
		EU, FR				DK/CH/AU/NZ				GB 230V				GB 110V	
		33-2M PC 33-2M IC	44-2M PC 44-2M IC	33-2H PC 33-2H IC	44-2H PC 44-2H IC	33-2M PC 33-2M IC	44-2M PC 44-2M IC	33-2H PC 33-2H IC	44-2H PC 44-2H IC	33-2M PC 33-2M IC	44-2M PC 44-2M IC	33-2M PC 33-2M IC	44-2M PC 44-2M IC	33-2M PC 33-2M IC	44-2M PC 44-2M IC
Possible voltage	V	220-240	220-240	220-240	220-240	220-240	220-240	220-240	220-240	220-240	220-240	220-240	220-240	110-120	110-120
Power P _{IEC}	W	1200	1200	1195	1195	1200	1200	1195	1195	1200	1200	1200	1200	1000	1000
Connected load for appliance socket	W	2400	2400	2400	2400	1100	1100	1100	1100	1700	1700	1700	1700	750	750
Mains frequency	Hz	50/60	50/60	50/60	50/60	50/60	50/60	50/60	50/60	50/60	50/60	50/60	50/60	50/60	50/60
Fuse	A	16	16	16	16	10	10	10	10	13	13	13	13	16	16
Protection grade (moist, dust)		IPX4													
Protection class (electrical)		I													
Max. Airflow *	l/s m ³ /h CFM					75	270	159					70	252	148
Max. Vacuum	kPa hPa in _{-H₂O}					25	250	100					23	230	92
Sound pressure level L _{PA} (IEC 60335-2-69)	dB(A)	69 ± 2													
Working sound level	dB(A)	60 ± 2													
Vibration ISO 5349 a _h	m/s ²	≤ 2,5													
Weight	kg lb	14,5 31,9	16 35,3	14,5 31,9	16 35,3	14,5 31,9	16 35,3	14,5 31,9	16 35,3	14,5 31,9	16 35,3	14,5 31,9	16 35,3	14,5 31,9	16 35,3
Filter surface area	m ²	0,5													
Dust class		M	M	H	H	M	M	H	H	M	M	M	M	M	M

* measured at turbine

Specifications and details are subject to change without prior notice.

NILFISK

EU / UE / EL / EC / EE / ES / EÚ / AB / EG

Declaration of Conformity

Prohlášení o shodě
Konformitätserklärung
Overensstemmelseserklæring
Declaración de conformidad
Vastavusdeklaratsioon
Déclaration de conformité
Vaatimustenmukaisuusvakuutus

Декларация за съответствие
Δήλωση συμμόρφωσης
Megfelelősségi nyilatkozat
Izjava o skladnosti
Dichiarazione di conformità
Atitikties deklaracija
Atbilstības deklarācija
Samsvarserklæring
Conformiteitsverklaring

Declaração de conformidade
Deklaracija zgodności
Declaratie de conformitate
Декларация о соответствии
Försäkran om
överensstämmelse
Vyhlášení o zhode
Izjava o skladnosti
Uygunluk beyanı

Manufacturer / Výrobce / Hersteller / Fabrikant /
Fabricante / Κατασκευαστής / Gyártó / Proizvođač /
Fabbricante / Gamintojas / Ražotājs / Produsent /
Fabrikant / Fabricante / Producent / Producător /
производитель / Tillverkaren / Výrobca /
Proizvajalec/ Üretici firma:

**Nilfisk A/S, Kornmarksvej 1
DK-2605 Broendby, DENMARK**

Product / Produkt / Producto, Toode, Produit, Tuote/
Продукт / Προϊόν / Termék / Proizvod / Prodotto /
Produktas / Produkts / Artikel / Produtos / Produs /
Izdelek / Ürün

ATTIX 33-*M/H-, 44-*M/H-** 1)**

Description / Popis / Beschreibung / Beskrivelse /
Descripción / Kirjeldus / La description / Kuvaus /
Описание / Περιγραφή / Leirás / Opis / Descrizione
/ Aprašymas / Apraksts / Beschrijving / Descrição /
Descriere / Beskrivning / Popis / Açıklama

**VAC - Commercial - Wet/Dry
110-120V, 220-240V 50-60Hz, IPX4**

EN

We, Nilfisk hereby declare under our sole responsibility, that the above-mentioned product(s) is/are in conformity with the following directives and standards.

LT

Mes, „Nilfisk“, prisiimdami visišką atsakomybę pareiškiame, kad pirmiau minėtas produktas (-ai) atitinka šias direktyvas ir standartus

CS

My, Nilfisk prohlašujeme na svou výlučnou odpovědnost, že výše uvedený výrobek je ve shodě s následujícími směrnici a normami.

LV

Mēs, Nilfisk, ar pilnu atbildību apliecinām, ka iepriekšminētais produkts atbilst šādām direktīvām un standartiem

DE

Wir, Nilfisk erklären in alleiniger Verantwortung, dass das oben genannte Produkt den folgenden Richtlinien und Normen entspricht.

NO

Vi, Nilfisk erklærer herved under eget ansvar, at det ovennevnte produktet er i samsvar med følgende direktiver og standarder

DA

Vi, Nilfisk erklærer hermed under eget ansvar at ovennævnte produkt(er) er i overensstemmelse med følgende direktiver og standarder.

NL

We verklaren Nilfisk hierbij op eigen verantwoordelijkheid, dat het bovengenoemde product voldoet aan de volgende richtlijnen en normen

ES

Nosotros, Nilfisk declaramos bajo nuestra única responsabilidad que el producto antes mencionado está en conformidad con las siguientes directivas y normas

PT

Nós, a Nilfisk declaramos, sob nossa exclusiva responsabilidade, que o produto acima mencionado está em conformidade com as diretrizes e normas a seguir

ET

Meie, Nilfisk Käesolevaga kinnitame ja kanname ainuisikulist vastutust, et eespool nimetatud toode on kooskõlas järgmiste direktiivide ja

PL

My, Nilfisk Niniejszym oświadczamy z pełną odpowiedzialnością, że wyżej wymieniony produkt jest zgodny z następującymi dyrektywami i normami..



Nilfisk déclare sous notre seule responsabilité que le produit mentionné ci-dessus est conforme aux directives et normes suivantes.



Noi, Nilfisk Prin prezenta declarăm pe propria răspundere, că produsul mai sus menționat este în conformitate cu următoarele standarde și directive



Me, Nilfisk täten vakuutamme omalla vastuulla, että edellä mainittu tuote on yhdenmukainen seuraavien direktiivien ja standardien mukaisesti



Мы, Nilfisk настоящим заявляем под нашу полную ответственность, что вышеперечисленные продукция соответствует следующим директивам и стандартам.



Ние, Nilfisk С настоящото декларираме на своя лична отговорност, че посочените по-горе продуктът е в съответствие със следните директиви и стандарти.



Vi Nilfisk förklarar härmed under eget ansvar att ovan nämnda produkt överensstämmer med följande direktiv och normer.



Εμείς, Nilfisk δηλώνουμε με αποκλειστική μας ευθύνη, ότι το προαναφερόμενο προϊόν συμμορφώνεται με τις ακόλουθες οδηγίες και πρότυπα.



My, Nilfisk prehlasujeme na svoju výlučnú zodpovednosť, že vyššie uvedený výrobok je v zhode s nasledujúcimi smernicami a normami.



Mi, Nilfisk Kijelentjük, egyedüli felelősséggel, hogy a fent említett termék megfelel az alábbi irányelveknek és szabványoknak



Mi, Nilfisk izjavljamo s polno odgovornostjo, da je zgoraj omenjeni izdelek v skladu z naslednjimi smernicami in standardi.



Mi, Nilfisk Izjavljujemo pod punom odgovornošću, da gore navedeni proizvod u skladu sa sljedećim direktivama i standardima.



Nilfisk, burada yer alan tüm sorumluluklarımıza göre, yukarıda belirtilen ürünün aşağıdaki direktifler ve standartlara uygun olduğunu beyan ederiz.



Noi, Nilfisk dichiara sotto la propria responsabilità, che il prodotto di cui sopra è conforme alle seguenti direttive e norme.

2006/42/EC	EN 60335-1:2012+A11:2014+A13:2017 +A1:2019+A14:2019+A2:2019+A15:2021 EN 60335-2-69:2012
2014/30/EU	EN 55014-1:2017+A11:2020 EN 55014-2:2015 EN 61000-3-2:2014 EN 61000-3-3:2013
2011/65/EU	EN 63000:2018

1) First asterisk means feature class. 0 = Standard/Basic type; 2 = Auto on/off for power outlet.

Second and third asterisk means filter cleaning options.

PC = Push&Clean; IC = InfiniClean

Authorized to compile
Technical File and
signatory:

Mads Christensen, VP R&D, Head of Competence Center Europe
• R&D

March 22, 2023



UK Declaration of Conformity

We,
Nilfisk Ltd
Nilfisk House, Bowerbank Way Gilwilly Industrial Estate
Penrith Cumbria
CA11 9BQ UK

Hereby declare under our sole responsibility that the

Products: VAC - Commercial - Wet/Dry
Description: 220-240V 50-60Hz, IPX4
Type: ATTIX 33-*M/H-**, 44-*M/H-** where

First asterisk means feature class.
0 = Standard/Basic type; 2 = Auto on/off for power outlet.
Second and third asterisk means filter cleaning options.
PC = Push&Clean; IC = InfiniClean

Are in compliance with the following standards:

EN 60335-1:2012+A11:2014+A13:2017
EN 60335-2-69:2012
EN 55014-1:2017+A11:2020
EN 55014-2:2015
EN 61000-3-2:2014
EN 61000-3-3:2013
EN 63000:2018

Following the provisions of:

Supply of Machinery (Safety) Regulations 2008/1597
Electromagnetic Compatibility Regulations 2016/1091
The Restriction of the Use of Certain Hazardous Substances in Electrical and Electronic Equipment
Regulations 2012/3032

Penrith, 20-1-2021

A handwritten signature in black ink, appearing to read 'Stewart Dennett', is written over a light blue horizontal line.

Stewart Dennett
GM/MD

HEAD QUARTER

DENMARK

Nilfisk A/S
Tel.: +45 43 23 81 00
www.nilfisk.com

SALES COMPANIES

ARGENTINA

Nilfisk Argentina
Tel.: +54 11 4737 1877
www.nilfisk.com

AUSTRALIA

Nilfisk Pty Ltd
Tel.: +61 1300 556 710
www.nilfisk.com

AUSTRIA

Nilfisk GmbH
Tel.: +43 (0)662/45 64 00-90
www.nilfisk.com

BELGIUM

Nilfisk nv/sa
Tel.: +32 (0) 2 467 60 50
www.nilfisk.com

BRAZIL

Nilfisk do Brasil
Tel.: +55 11 3959-0300
www.nilfisk.com

CANADA

Nilfisk Canada Company
Tel.: +1 800-668-8400
www.nilfisk.com

CHILE

Nilfisk S.A. (Comercial KCS Ltda)
Tel.: +56 2 2684 5000
www.nilfisk.com

CHINA

Nilfisk
Tel.: +86 400 080 3200
www.nilfisk.com

CZECH REPUBLIC

Nilfisk s.r.o.
Tel.: +420 244 090 912
www.nilfisk.com

DENMARK

Nilfisk Danmark A/S
Tel.: +45 72 18 21 00
www.nilfisk.com

FINLAND

Nilfisk Oy Ab
Tel.: +358 207 890 602
www.nilfisk.com

FRANCE

Nilfisk SAS
Tel.: +33 169 59 87 00
www.nilfisk.com

GERMANY

Nilfisk GmbH
Tel.: +49 (0)7306-72-444
www.nilfisk.com

GREECE

Nilfisk A.E.
Tel.: +30 210 911 9600
www.nilfisk.com

NETHERLANDS

Nilfisk B.V.
Tel.: +31 036-5460700
www.nilfisk.com

HUNGARY

Nilfisk Kft.
Tel.: +36 24 507 452
www.nilfisk.com

INDIA

Nilfisk India Limited
Tel.: +91 80 4127 6510
www.nilfisk.com

IRELAND

Nilfisk
Tel.: +35 01 294 3838
www.nilfisk.com

ITALY

Nilfisk SpA
Tel.: +39 0523 1612000
www.nilfisk.com

JAPAN

Nilfisk Inc.
Tel.: +81 045-620-3658
www.nilfisk.com

MALAYSIA

Nilfisk Sdn Bhd
Tel.: +603 6275 3120
www.nilfisk.com

MEXICO

Nilfisk de Mexico, S. de R.L. de C.V.
Tel.: +52 442 427 7774
www.nilfisk.com

NEW ZEALAND

Nilfisk Limited
Tel.: +64 (09) 525 1130
www.nilfisk.com

NORWAY

Nilfisk AS
Tel.: +47 22 75 17 80
www.nilfisk.com

PERU

Nilfisk S.A.C.
Tel.: + 51 (1) 710 8283
www.nilfisk.com

POLAND

Nilfisk Sp. Z.O.O.
Tel.: +48 22 104 22 00
www.nilfisk.com

PORTUGAL

Nilfisk Lda.
Tel.: +351 219 112 670
www.nilfisk.com

SINGAPORE

Nilfisk Pte Ltd
Tel.: +65 62681006
www.nilfisk.com

SLOVAKIA

Nilfisk s.r.o.
Tel.: +421 948 339 353
www.nilfisk.com

SOUTH AFRICA

Nilfisk Middle East & Africa
Tel.: +971 4264 4172
www.nilfisk.com

SOUTH KOREA

Nilfisk Korea
Tel.: +82 02-3474-4141
www.nilfisk.com

SPAIN

Nilfisk S.A.U
Tel.: +34 900 506 776
www.nilfisk.com

SWEDEN

Nilfisk AB
Tel.: +46 031-706 73 00
www.nilfisk.com

SWITZERLAND

Nilfisk AG
Tel.: +41 (0)71 923 84 44
www.nilfisk.com

THAILAND

Nilfisk Co. Ltd.
Tel.: +66 0-2275-5630
www.nilfisk.com

TURKEY

Nilfisk A.S.
Tel.: +90 216 275 76 00
www.nilfisk.com

UNITED ARAB EMIRATES

Nilfisk Middle East Branch
Tel.: +971 4264 4172
www.nilfisk.com

UNITED KINGDOM

Nilfisk Ltd.
Tel.: +44 01768 868995
www.nilfisk.com

UNITED STATES

Nilfisk, Inc.
Tel.: +1 800-989-2235
www.nilfisk.com

VIETNAM

Nilfisk Vietnam
Tel.: +84 0866 461 566
www.nilfisk.com